

ASSEMBLY INSTRUCTIONS

ITEM NO: DINING TABLE



Read instruction carefully prior for assembly

Thank you for purchasing this product . Be sure to check all packing material carefully for small parts that may have come loose inside the carton during shipment .



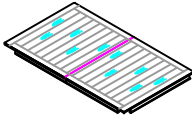

Remove all components from pack and place on soft surface to prevent scratch during assembly. Identify and count all parts as specified below

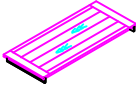
It is recommended to use two people during the assembly process.

PARTS LIST:

No.	Description	Quantity
A	Table Top 	1PC
B	Leg 	4PCS
C	Leaf 	1PC

HARDWARE LIST:

No.	Description	Sketch	Size	Quantity
H1	Lock Washer		Ø 5/16"	8 Pcs
H2	Flat Washer		Ø 5/16"	8 Pcs
H3	Hex Nut		Ø 5/16"	8 Pcs
H4	Open Wrench		10mm	1 Pc

STEP 1:

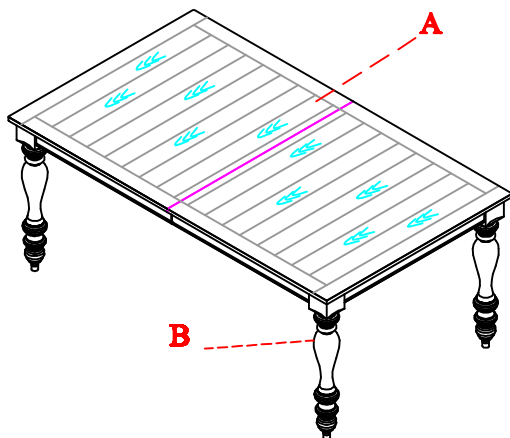

Release corner MDF support from table top

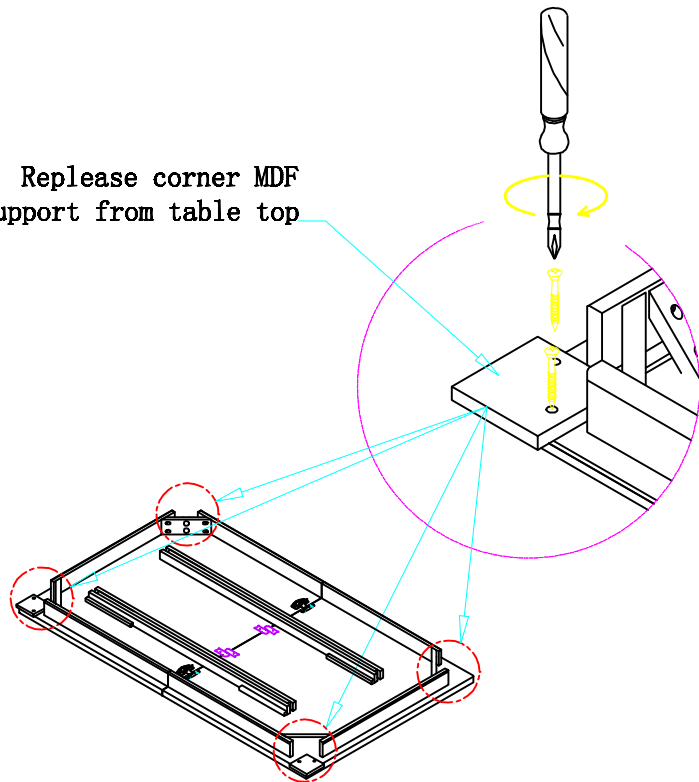

STEP 1 : Turn Table top upside down and put on soft surface such as carpet or cloth and then take out wood protect on table top using by phillips screw driver (not included).

ASSEMBLY INSTRUCTIONS

ITEM NO: DINING TABLE

STEP 2:

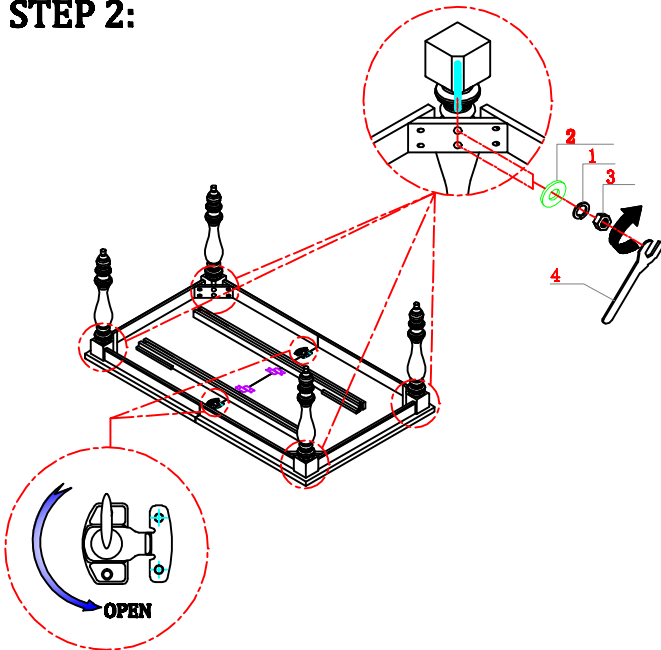

STEP 3:

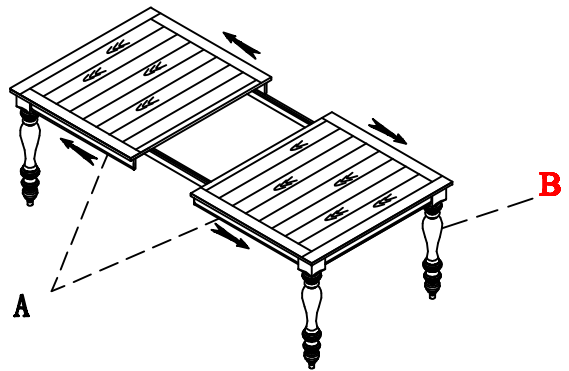

Step 2: Attach Leg (B) to Table Top (A) using Flat Washer (2), Lock Washer (1), hex nut (3) by using open wrench (4) and Unlock the Table .

Step 3: Pull out Table Top each side .

STEP 4:

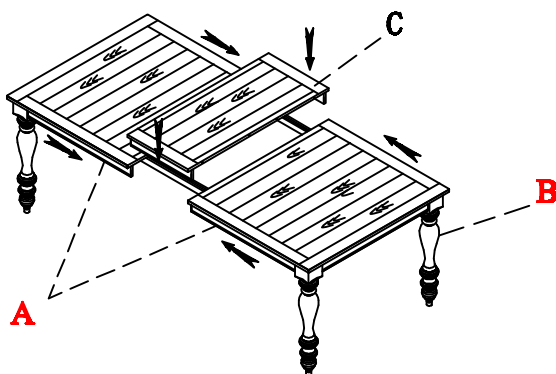

STEP 5:

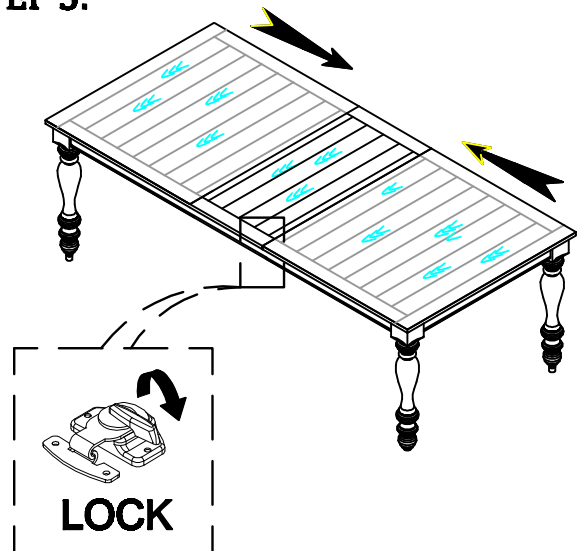

Step 4: Put Leaf (C) to Table Top (A) .

Step 5: Push two side tops that reach these leafs then lock them by using Sash lock .

ASSEMBLY INSTRUCTIONS





ITEM NO: SIDE UPH CHAIR

Read instruction carefully prior to assembly.

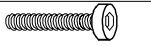

Thank you for purchasing this quality product. Check carefully for small parts which may come loose during shipment. Remove all components from pack and place top down on soft surface such as carpet or cloth to prevent scratching the finish. Identify and count all parts as specified below.

It is recommended to use one person during the assembly process.

HARDWARE LIST:

No.	Description	Sketch	Size	Qty
H1	Allen Bolt		Ø1/4 x 75mm	4 PCS
H2	Allen Bolt		Ø1/4 x 38mm	2 PCS
H3	Allen Bolt		Ø1/4 x 50mm	4 PCS
H4	Flat Washer		Ø5/16 x 18 mm	10 PCS
H5	Lock Washer		Ø5/16	10 PCS
H6	Allen Key		4 mm	1 PCS

PARTS LIST:

No.	Description	Sketch	Quantity
A	Chair Back		1 PC
B	Seat cushion		1 PC
C	Front Leg		2 PCS

Step 1

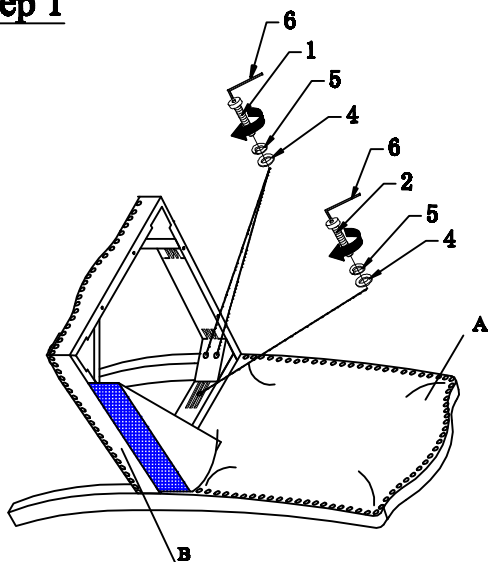

Step 1: Place the Chair Back (A) on the floor. Attach Seat Cushion (B) to the Chair Back (A) by using Flat Washer (4), Lock Washer (5), Allen Bolt (1) into the holes at the corner block of the Seat Cushion (B). Insert Flat Washer (4), Lock Washer (5), Allen Bolt (2) into the rear bar of the seat frame. Secure by Allen Key (6).

Step 2

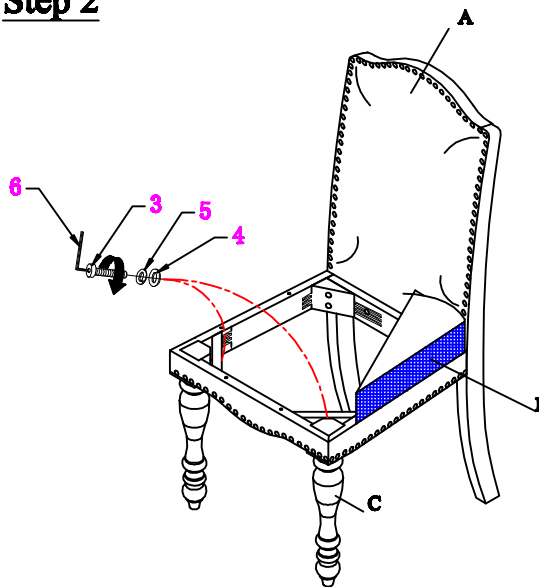

Step 2: Attach Front Leg (C) to the Seat Cushion (B) by inserting Flat Washer (4), Lock Washer (5), Allen Bolt (3) and secure with Allen Key (6) Assembly product is now completed.

ASSEMBLY INSTRUCTIONS

ITEM NO: SQUARE COUNTER PUB TABLE



Read instruction carefully prior for assembly

Thank you for purchasing this product . Be sure to check all packing material carefully for small parts that may have come loose inside the carton during shipment .





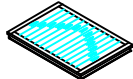

Remove all components from pack and place on soft surface to prevent scratch during assembly. Identify and count all parts as specified below

It is recommended to use two people during the assembly process.

PARTS LIST:

No.	Description		Quantity
A	Table Top		1PC
B	Shelf panel		2PCS
C	Leg		4PCS

HARDWARE LIST:

No.	Description	Sketch	Size	Quantity
H1	Lock Washer		Ø5/16"	16 Pcs
H2	Flat Washer		Ø5/16"	16 Pcs
H3	Hex Nut		Ø 5/16"	8 Pcs
H4	Allen Bolt		Ø5/16 x 50mm	8 Pcs
H5	Allen Key		4 mm	1 Pc
H6	Open Wrench		10mm	1 Pc

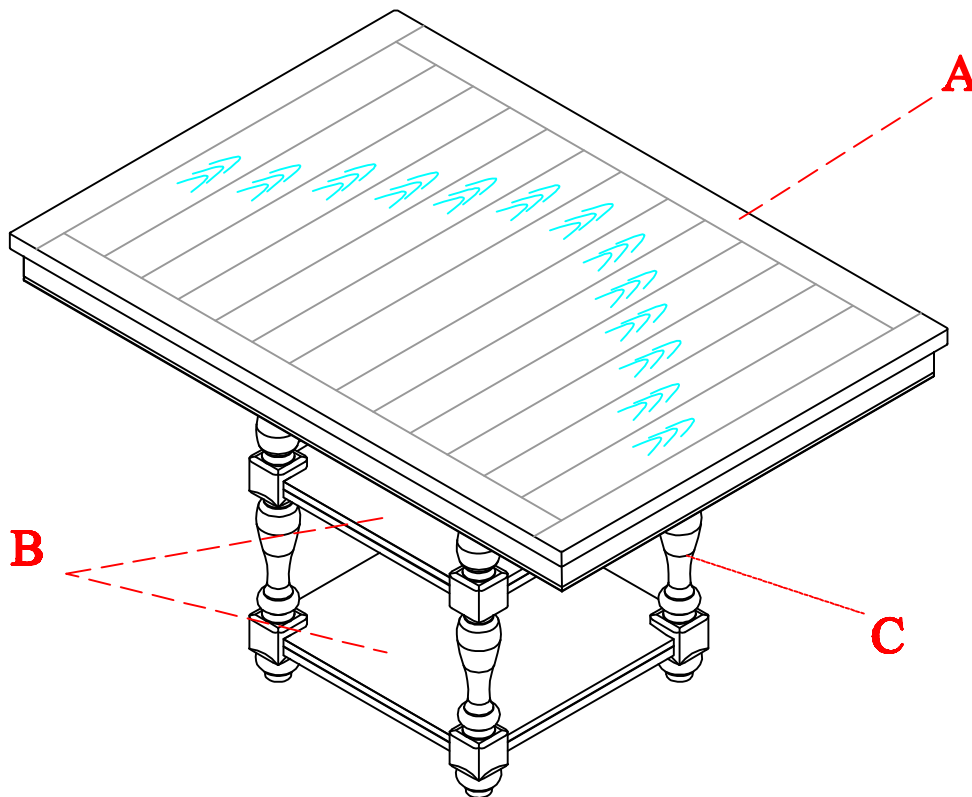

ASSEMBLY INSTRUCTIONS

ITEM NO: SQUARE COUNTER PUB TABLE

STEP 1:

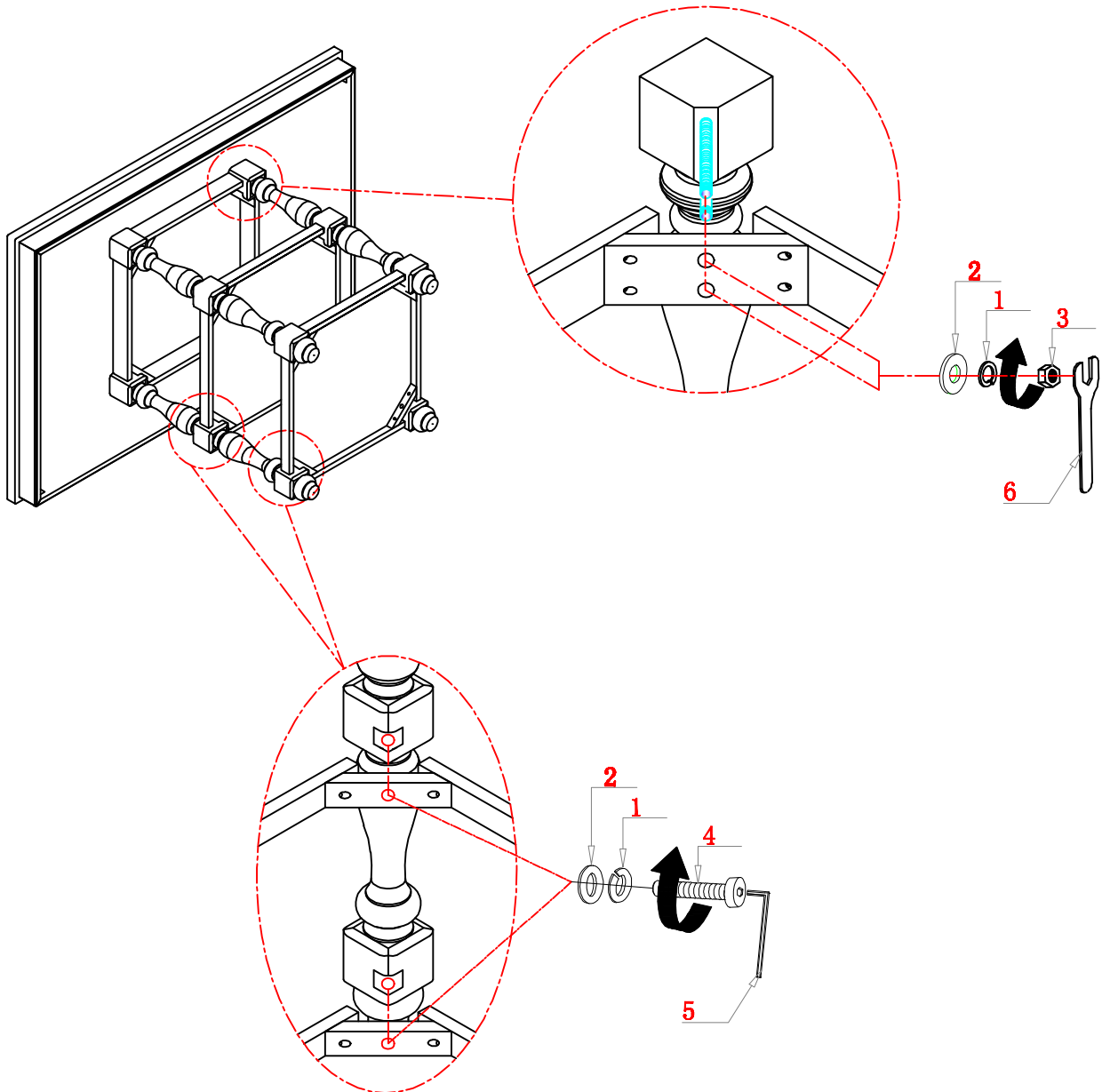

Step 1: Attach Leg (C) to Stretcher panel (B) and Table Top (A) using Flat Washer (2), Lock Washer (1), Allen Bolt (4) by Allen Key (5) For Stretcher panel (B) and hex nut (3) by open wrench (6) For Table Top .

ASSEMBLY INSTRUCTIONS

ITEM NO: UPH COUNTER CHAIR

Read instruction carefully prior to assembly.







Thank you for purchasing this quality product. Check carefully for small parts which may come loose during shipment. Remove all components from pack and place top down on soft surface such as carpet or cloth to prevent scratching the finish. Identify and count all parts as specified below.

It is recommended to use one person during the assembly process.





TOOLS REQUIRED (NOT INCLUDED)

Description	Sketch
Screw Driver	

HARDWARE LIST:

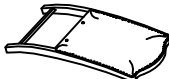
No.	Description	Sketch	Size	Qty
H1	Allen Bolt		Ø1/4 x 75mm	4 PCS
H2	Allen Bolt		Ø1/4 x 38mm	2 PCS
H3	Allen Bolt		Ø1/4 x 50mm	4 PCS
H4	Flat Washer		Ø5/16 x 18 mm	10 PCS
H5	Lock Washer		Ø5/16	10 PCS
H6	Pan Head Screw		Ø8 X 38 mm	6 PCS
H7	Allen Key		4 mm	1 PC

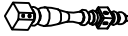
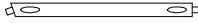
PARTS IDENTIFICATION

No.	Description	Sketch	Quantity
A	Chair Back		1 PC
B	Seat Cushion		1 PC
C	Front Leg		2 PCS
D	Side Stretcher		2 PCS
E	Front Stretcher		1 PC

Step 1

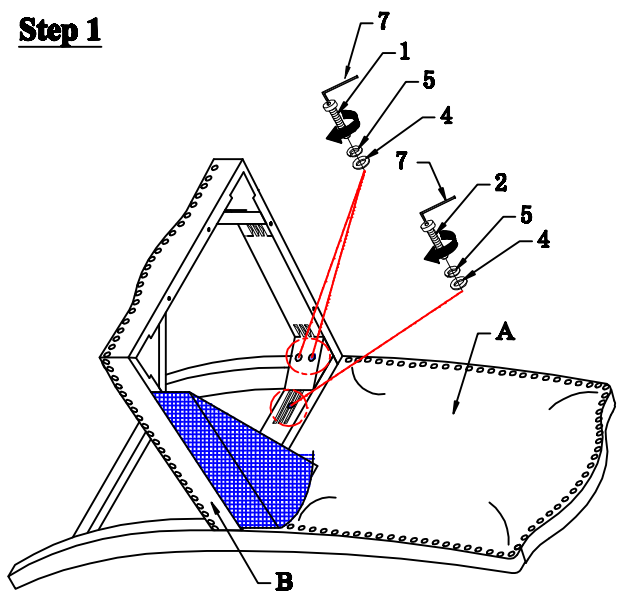

Step 1: Place the Chair Back (A) on the floor. Attach Seat Cushion (B) to the Chair Back (A) by using Flat Washer (4), Lock Washer (5), Allen Bolt (1) into the holes at the corner block of the Seat Cushion (B). Insert Flat Washer (4), Lock Washer (5), Allen Bolt (2) into the rear bar of the seat frame. Secure by Allen Key (7).

Step 2

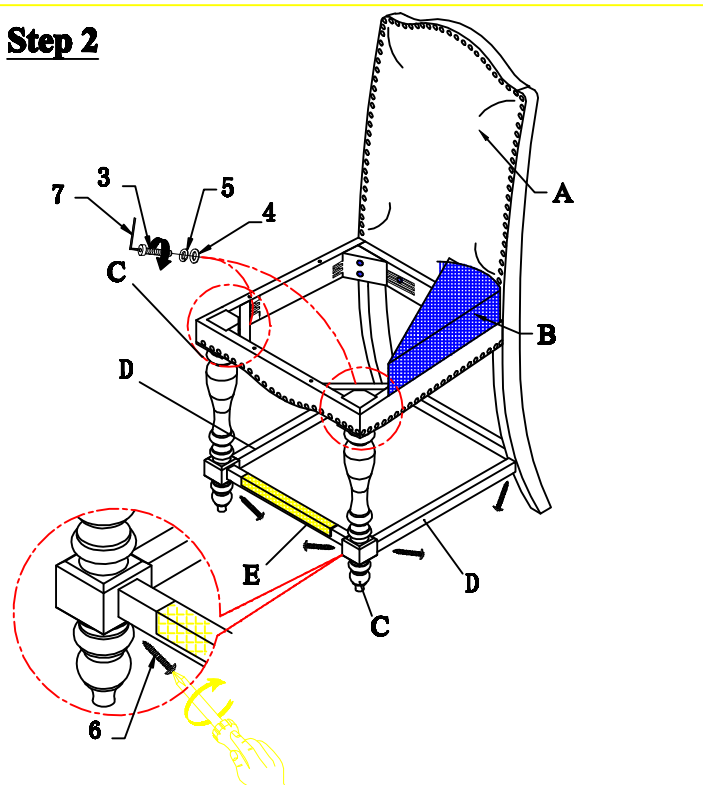

Step 2: Attach the front legs to seat Cushion using flat washer (4), lock washer (5) and Allen Bolt (3) by using Allen Key (7). Attach the front, left side, right side of Stretcher to Right, left of Front Leg and Chair back by securing the Pan Head Screw (6) with Phillips screw drivers (not included).

ASSEMBLY INSTRUCTIONS



ITEM NO: SERVER



Read instruction carefully prior for assembly

Thank you for purchasing this product . Be sure to check all packing material carefully for small parts that may have come loose inside the carton during shipment .

Remove all components from pack and place on soft surface to prevent scratch during assembly. Identify and count all parts as specified below

It is recommended to use two people during the assembly process.

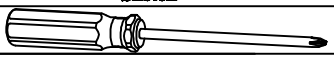
PARTS LIST:			
No.	Description		Quantity
A	Server		1 PC
B	Front Bunfeet		2 PCS
C	Back Bunfeet		2 PCS

TOOLS REQUIRED (NOT INCLUDED)			
Description	Sketch		
Screw Driver			
HARDWARE LIST			
No.	Description	Sketch	Q'ty
H	Tipping Restraint		1 SET

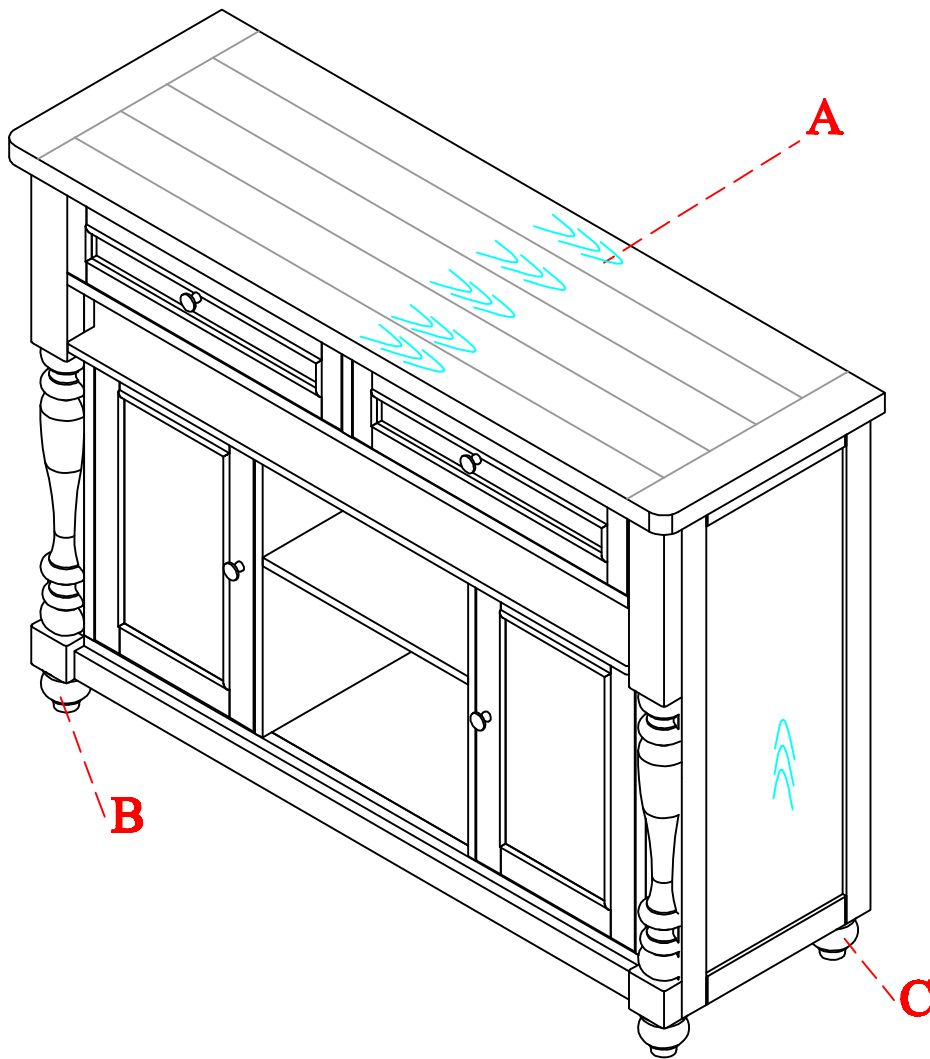

ASSEMBLY INSTRUCTIONS

ITEM NO: SERVER

STEP 1:

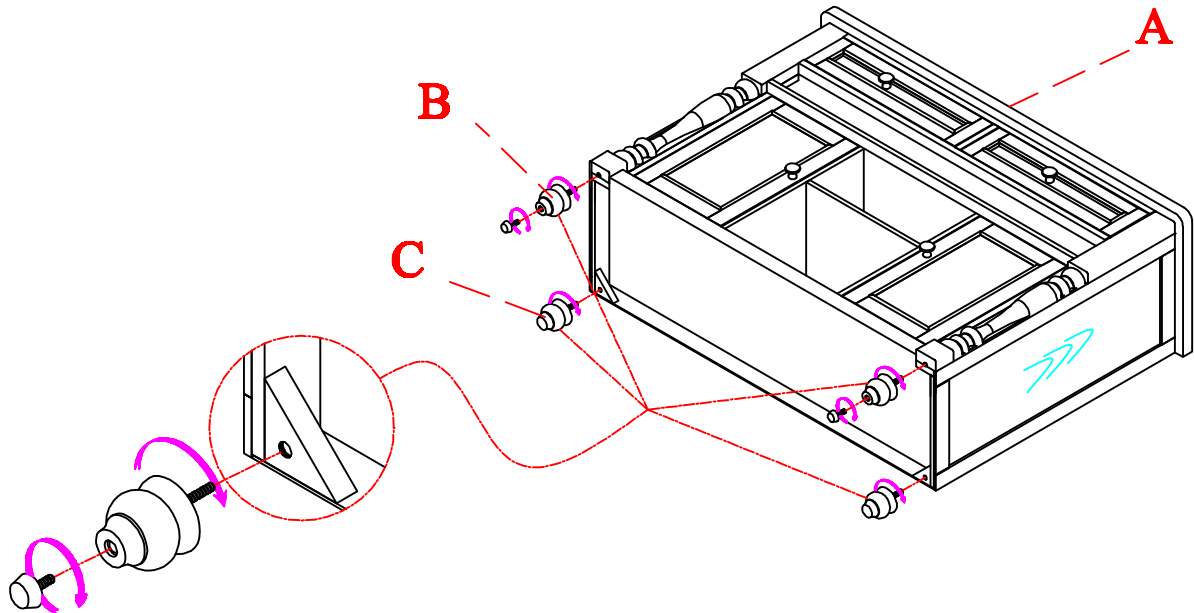

Step 1: Attach Front (B) and Back Bunfeet (C) to Server (A)

STEP 2:

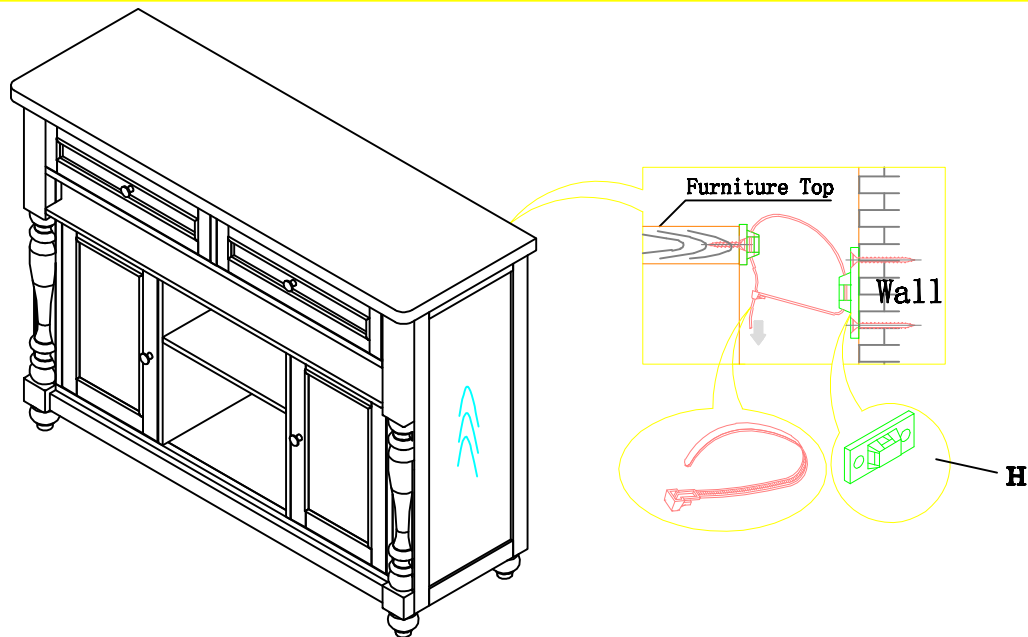

Step 2: Attach tipping restraint to Wall .

The tipping restraint must be attached at back of Server above and on the right .