

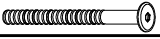

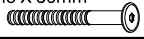

# ASSEMBLY INSTRUCTIONS

MODEL : ANDREW-DC-9

**IMPORTANT NOTE :** \* PLACE ALL WOODEN PARTS ON A CLEAN AND SMOOTH SUCH AS A RUG OR CARPET TO AVOID THE PARTS FROM BEING SCRATCHED.  
 \* BEFORE YOU BEING, KINDLY FOLLOW THE ASSEMBLY INSTRUCTIONS STEP BY STEP.  
 \* DO NOT TIGHTEN ALL SCREWS UNTIL THE CHAIR IS FULLY SET-UP.

HARDWARE LIST			PART LIST		
A	JCBC SCREW M6 X 80mm 	4PCS	1	CHAIR BACK	1PC
B	JCBC SCREW M6 X 50mm 	4PCS			
C	JCBC SCREW M6 X 40mm 	2PCS	2	FRONT LEG	2PCS
D	SPRING WASHER M6 	10PCS			
E	FLAT WASHER 5/16" 	10PCS	3	BOX SEAT	1PC
F	ALLEN KEY M4 	1PC			

**CAUTIONS :**

(1) **DO NOT FULLY-TIGHTEN THE NUT OR NUT BOLTS INITIALLY UNTIL ALL NUTS OR BOLT IS READY ASSEMBLED.**

(TO AVOID CAUSING DAMAGES TO THE THREAD, DO NOT OVER-TIGHTEN THE NUTS OR BOLTS.)

(2) **KEEP ALL HARDWARE PART OUT OF REACH OF CHILDREN.**

**STEP 1**

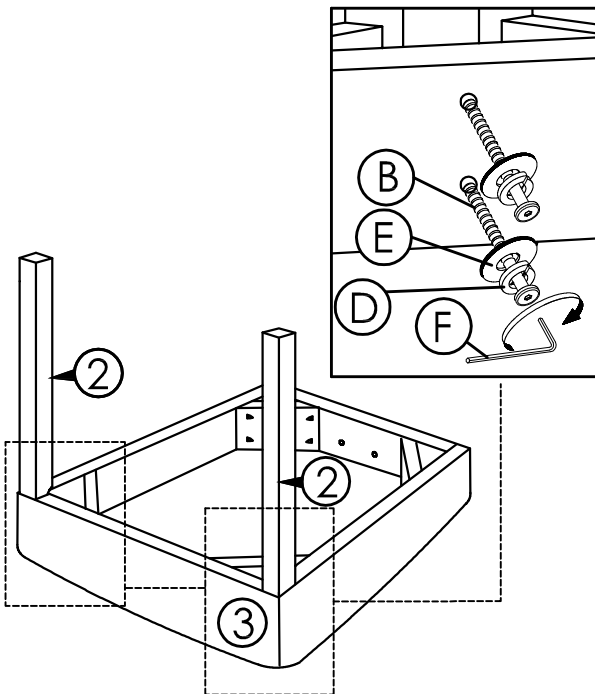

**STEP 2**

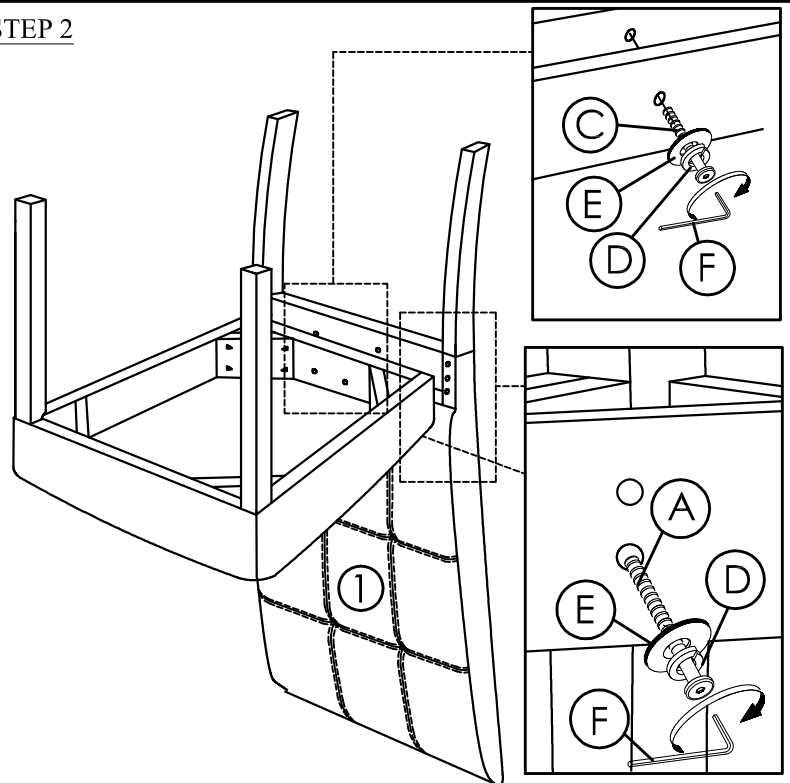

**STEP 3**

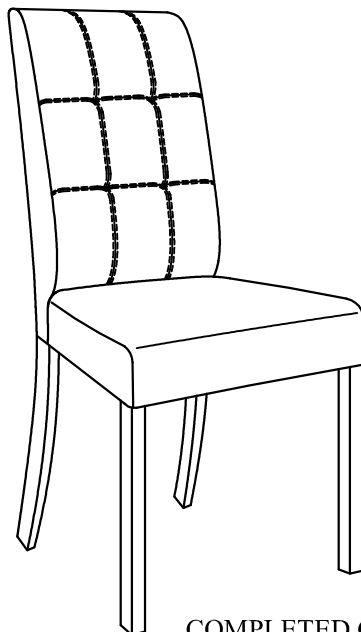

COMPLETED CHAIR ASSEMBLY.