

# ASSEMBLY INSTRUCTIONS

ITEM NO : C2180A-QXB / C2180-BXN

DESCRIPTION : QUEEN HEADBOARD / FOOTBOARD WITH SLATS / QUEEN SIDE RAIL

ITEM	DRAWING	DESCRIPTION	QTY
A		HEADBOARD	1
B		FOOTBOARD	1
C		LEG POST (L/R)	2
D		SIDE RAIL	2
E		SLAT	4

ITEM	DRAWING	DESCRIPTION	QTY
F		VERTICAL LEG	4
G		JCBB M8 x 40mm	6
H		SPRING WASHER M8	6
I		FLAT WASHER M8	6
J		ALLEN KEY M5	1
K		JCBB M6 x 35mm	4
L		ALLEN KEY M4	1
M		PANHEAD SCREW M4 x 32mm	8

## STEP 1

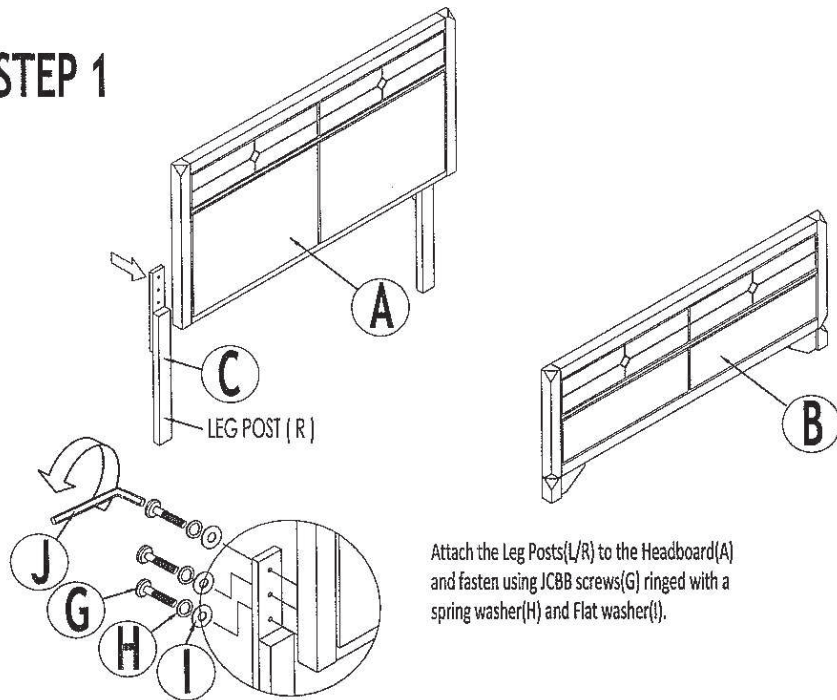

Attach the Leg Posts(L/R) to the Headboard(A) and fasten using JCBB screws(G) ringed with a spring washer(H) and Flat washer(I).

NOTE: SCREWS LOOSEN WITH USE.CHECK FOR LOOSE SCREWS AND TIGHTEN EVERY 6-8 WEEKS

### CLEANING INSTRUCTIONS:

Clean & polish all surfaces after assembly with a soft cloth and industrial furniture polish.

## STEP 2

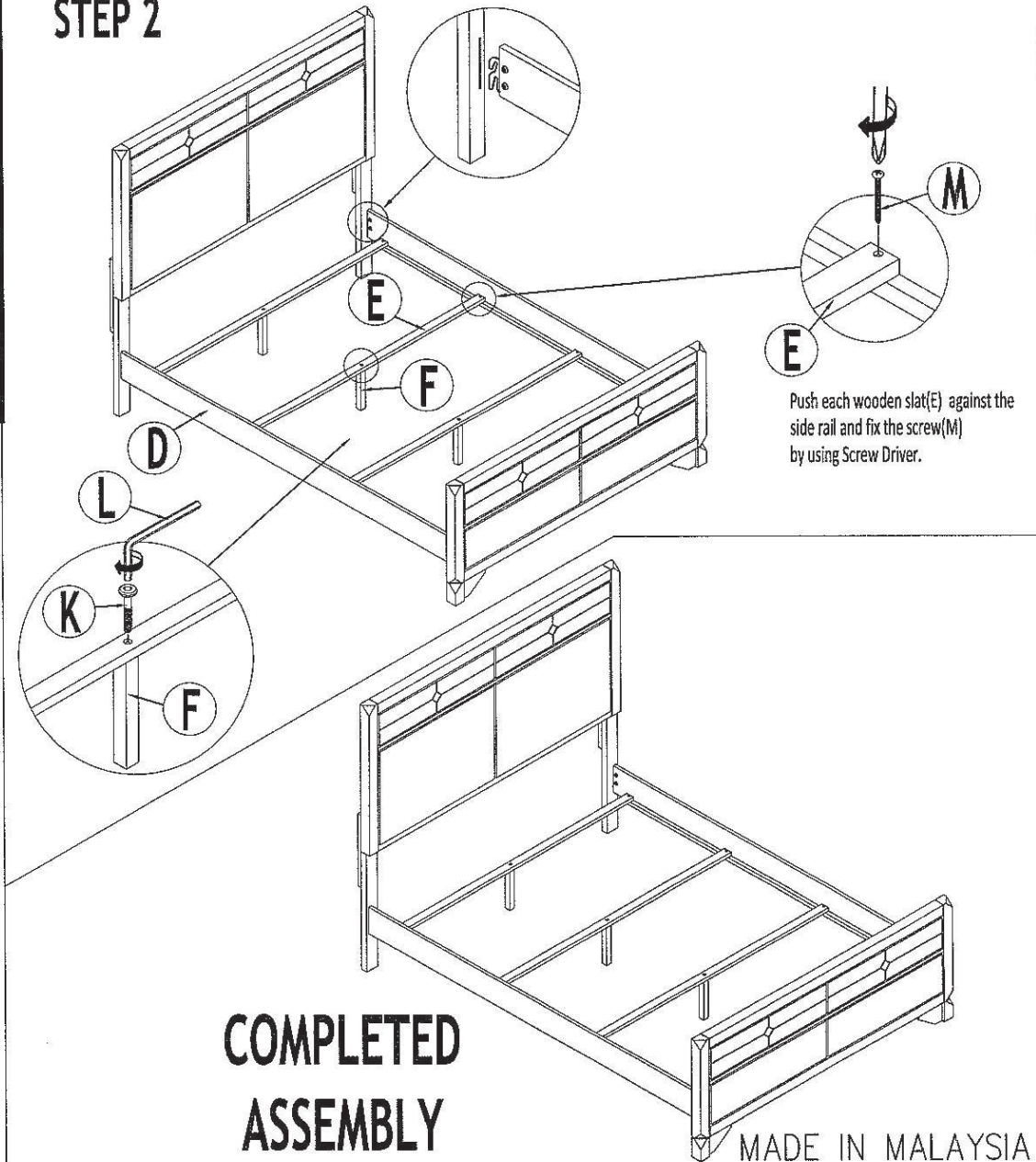

# ASSEMBLY INSTRUCTIONS

ITEM NO : C2180A-QXB / C2180A-BXN



DESCRIPTION : KING HEADBOARD / FOOTBOARD WITH SLAT / KING SIDE RAIL

ITEM	DRAWING	DESCRIPTION	QTY	ITEM	DRAWING	DESCRIPTION	QTY
A		HEADBOARD	1	F		VERTICAL LEG	8
B		FOOTBOARD	1	G		JCBB M8 x 40mm	6
C		LEG POST (L/R)	2	H		SPRING WASHER M8	6
D		SIDE RAIL	2	I		FLAT WASHER M8	6
E		SLAT	4	J		ALLEN KEY M5	1
				K		JCBC M6 x 35mm	8
				L		ALLEN KEY M4	1
				M		PANHEAD SCREW M4 x 32mm	8

## STEP 1

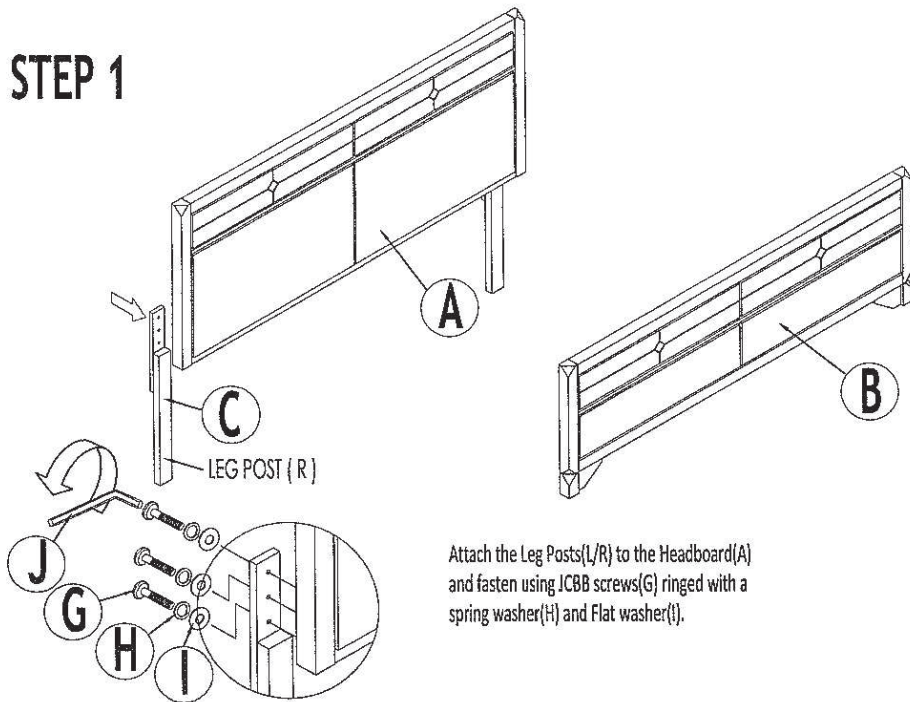

NOTE: SCREWS LOOSEN WITH USE. CHECK FOR LOOSE SCREWS AND TIGHTEN EVERY 6-8 WEEKS

### CLEANING INSTRUCTIONS:

Clean & polish all surfaces after assembly with a soft cloth and industrial furniture polish.

## STEP 2

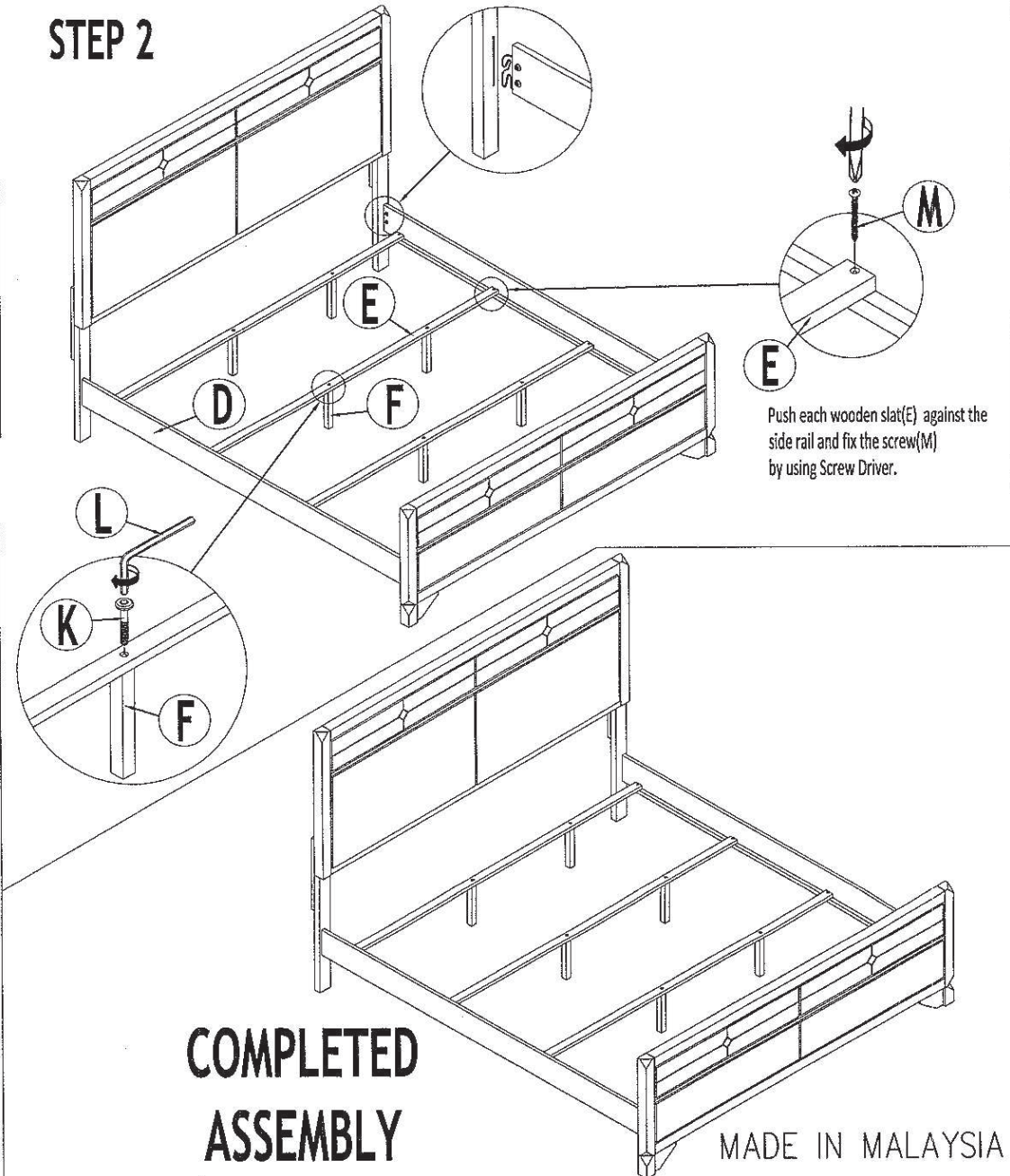



# ASSEMBLY INSTRUCTIONS

ITEM NO : C2180A-GXB / C2180A-CXO

DESCRIPTION : KING / C.K HEADBOARD / FOOTBOARD WITH SLAT / C.K SIDE RAIL

ITEM	DRAWING	DESCRIPTION	QTY	ITEM	DRAWING	DESCRIPTION	QTY
A		HEADBOARD	1	F		VERTICAL LEG	8
B		FOOTBOARD	1	G		JCBB M8 x 40mm	6
C		LEG POST (L/R)	2	H		SPRING WASHER M8	6
D		SIDE RAIL	2	I		FLAT WASHER M8	6
E		SLAT	4	J		ALLEN KEY M5	1
				K		JCBC M6 x 35mm	8
				L		ALLEN KEY M4	1
				M		CSK SCREW M3.5 x 12mm	16
				N		L BRACKET	8

## STEP 1

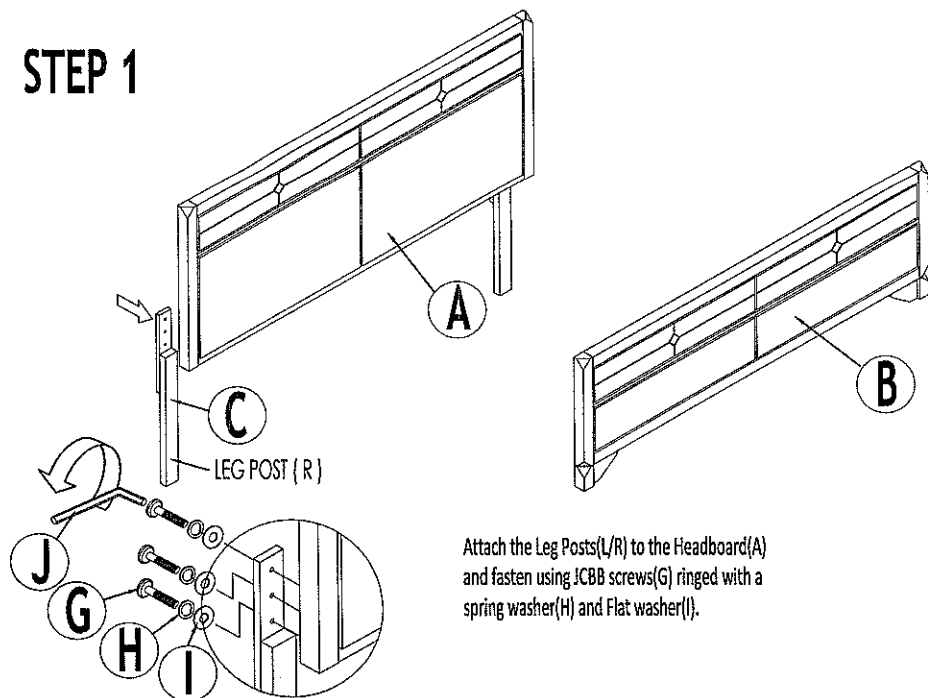

Attach the Leg Posts(L/R) to the Headboard(A) and fasten using JCBB screws(G) ringed with a spring washer(H) and Flat washer(I).

NOTE: SCREWS LOOSEN WITH USE. CHECK FOR LOOSE SCREWS AND TIGHTEN EVERY 6-8 WEEKS

### CLEANING INSTRUCTIONS:

Clean & polish all surfaces after assembly with a soft cloth and industrial furniture polish.

## STEP 2

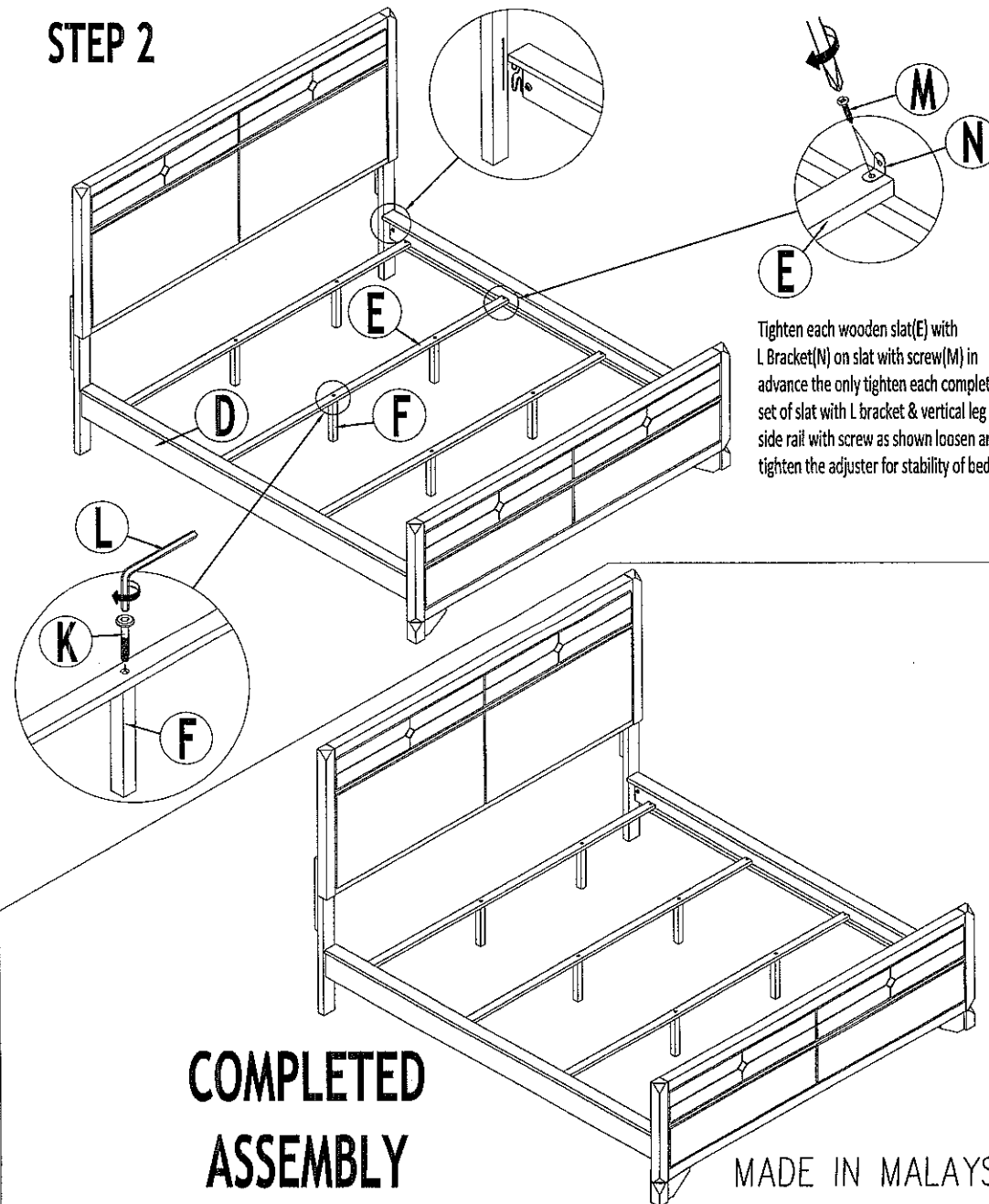

Tighten each wooden slat(E) with L Bracket(N) on slat with screw(M) in advance the only tighten each completed set of slat with L bracket & vertical leg on side rail with screw as shown loosen and tighten the adjuster for stability of bed.

**COMPLETED ASSEMBLY**

MADE IN MALAYSIA