

Read this instruction carefully. See hardware and furniture part list for guidance. Be sure all parts are complete, before you assemble. Place all wooden furniture parts on a clean and flat soft surface to prevent from being scratched. Follow the figure to start assembling.

CAUTIONS : 1. Do not FULLY - TIGHTEN the nut or nut bolt until all nut or bolt is ready assembled.
 2. Do not OVER - TIGHTEN the nut or bolt to avoid causing damages to the thread.
 3. Keep all hardware parts out of reach of children.

NOTE : THE LIST AND QUANTITY SHOWN ARE FOR 1 UNIT ASSEMBLY.

PART LIST		
ITEM	DESCRIPTION	QTY
A	HEADBOARD	1 PC
B	HEADBOARD LEG (L&R)	2 PCS
C	FOOTBOARD	1 PC
D	SIDE RAIL	2 PCS
E	CENTER RAIL	1 PC
F	CENTER SUPPORT	2 PCS
G	CENTER SUPPORT LEG	3 PCS
H	BED SLAT	24 PCS
I	BED LEG	2 PCS
J	HEADBOARD SUPPORT WOOD	2 PCS
K	HEADBOARD SUPPORT RAIL	1 PC

PART LIST		
ITEM	DESCRIPTION	QTY
1	JCBB BOLT M8 x 30mm	8 PCS
2	JCBC BOLT M8 x 50mm	10 PCS
3	M8 FLAT WASHER	10 PCS
4	M8 SPRING WASHER	10 PCS
5	WOOD SCREW M3.5 x 16mm	8 PCS
6	BED SLAT SIDE FITTER	24 PCS
7	BED SLAT CENTER FITTER	12 PCS
8	M5 ALLEN KEY (BALL SHAPE)	1 PC
9	PVC BLACK WASHER	2 PCS

STEP 1

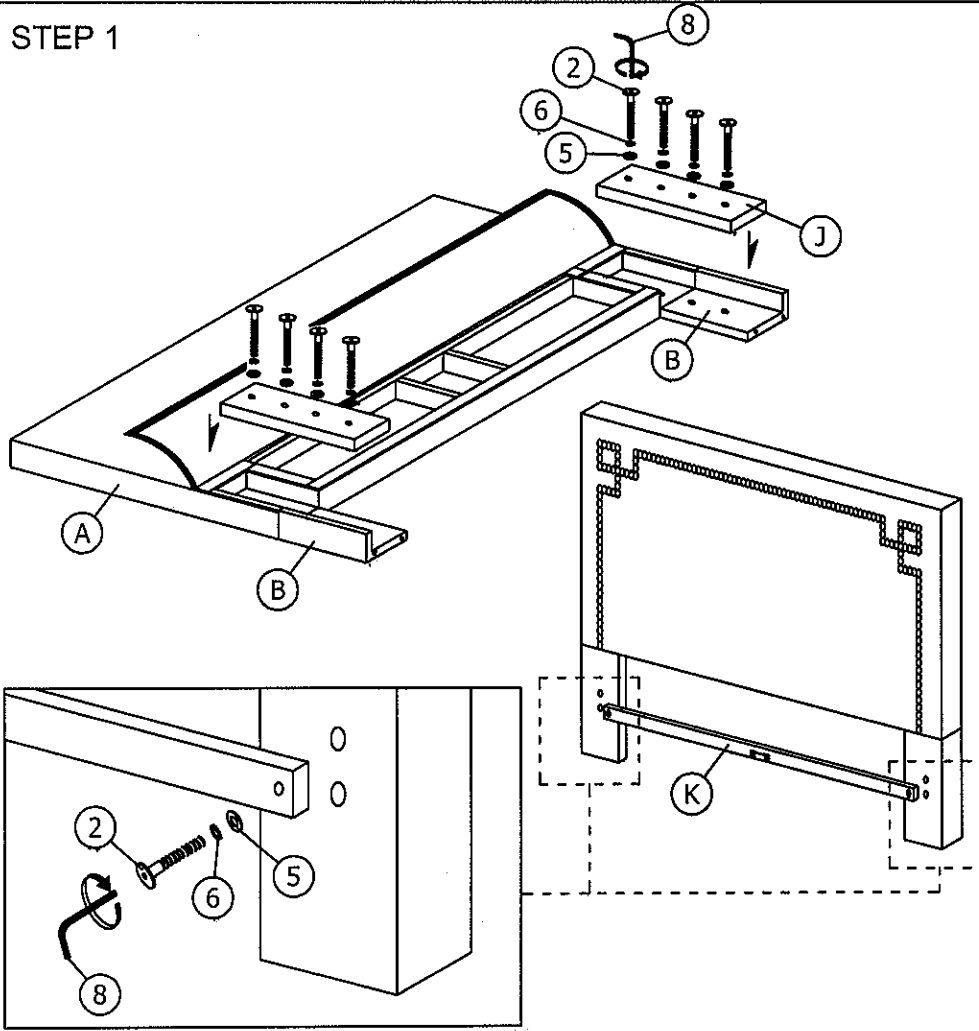

STEP 2

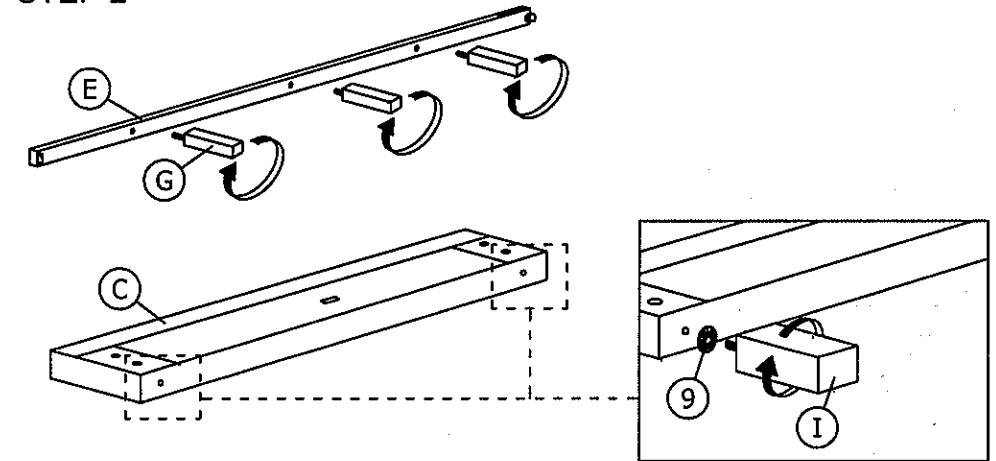

STEP 3

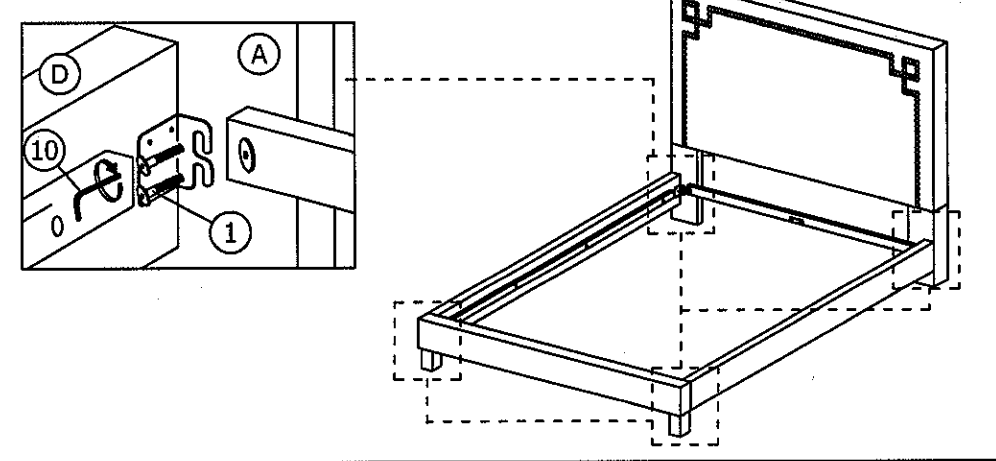

ASSEMBLY INSTRUCTIONS

STEP 4

Note: Make sure the sticker "-> HEADBOARD" faced to headboard [A]

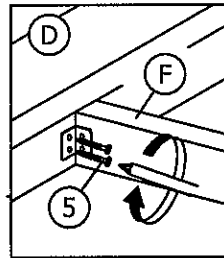
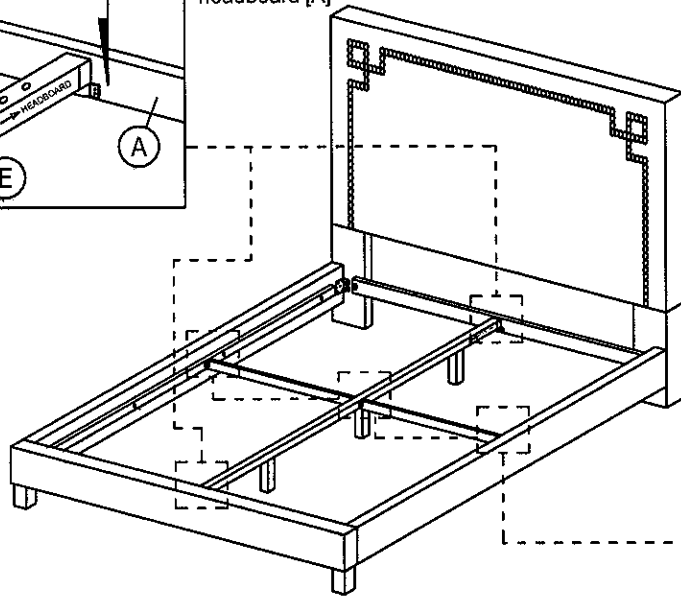
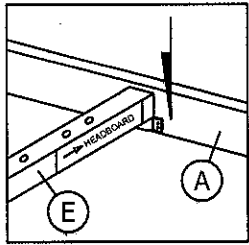

STEP 5

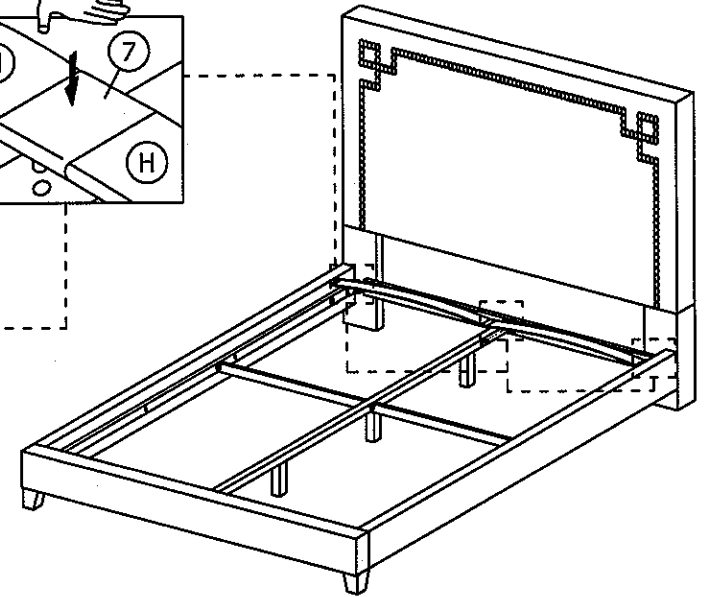
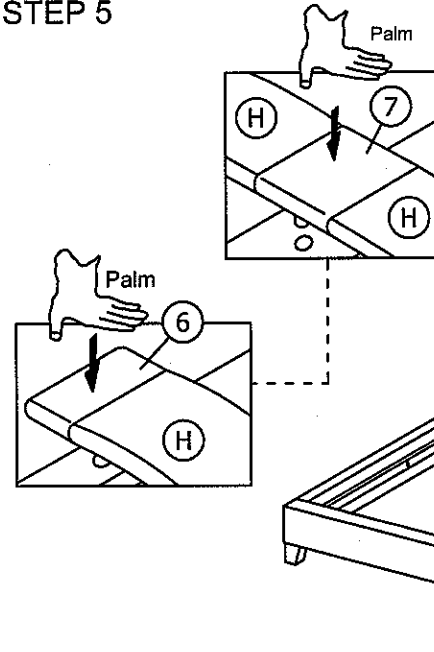

STEP 6

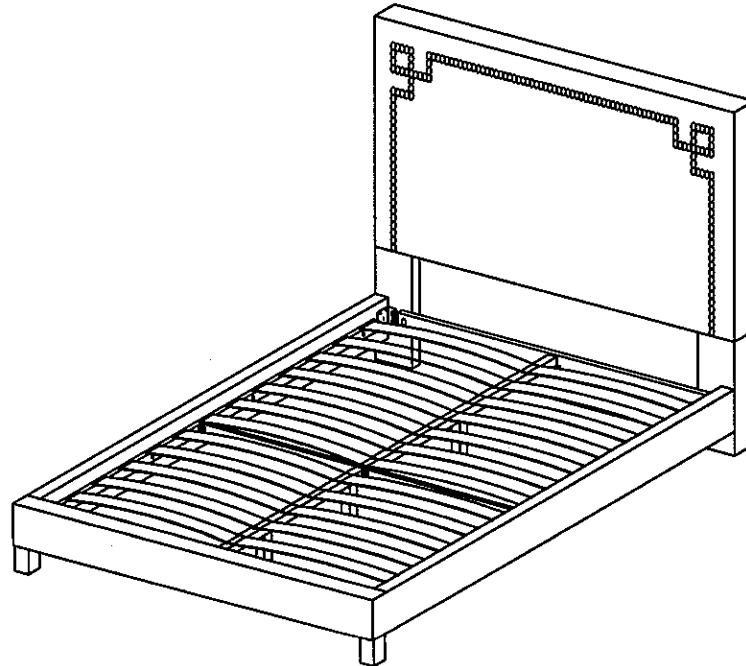

* When moving the bed position, the center support legs must be adjust to be straight to avoid any broken problem.