













ASSEMBLY INSTRUCTION

ITEM : WALDEN DAYBED

NO	PART LIST	QTY
1	 BACK PANEL	1PC
2	 RIGHT ARM	1PC
3	 LEFT ARM	1PC
4	 FRONT RAIL	1PC
5	 LEG	4PCS
6	 SLATS	2PCS
NO	HARDWARE LIST	QTY
A	 JCBC SCREW M8 x 20mm	8PCS
B	 JCBC SCREW M6 x 25mm	8PCS
C	 JCBC SCREW M6 x 50mm	2PCS
D	 SPRING WASHERS	10PCS
E	 FLAT WASHERS	2PCS
F	 SCREWS M4 x 65mm	8PCS
G	 L - KEY M4 x 65mm	1PC
H	 L - KEY M5 x 65mm	1PC

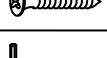
STEP 1

Begin assembly by attaching each leg (5) to the bottom of right arm (2) & left arm (3) by securing with 2 Allen Bolts (B) , 2 spring washer (D) per leg using L - key (G).

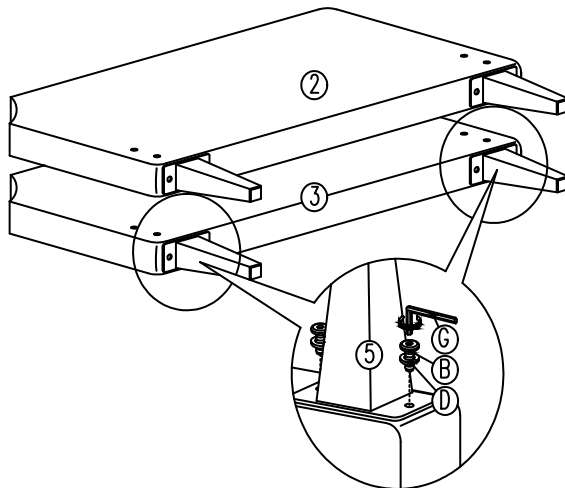

STEP 3

Securing with 1 Allen Bolt (C) , 1 spring washer (D) , 1 flat washer (E) each side of back panel by using L-key (G).

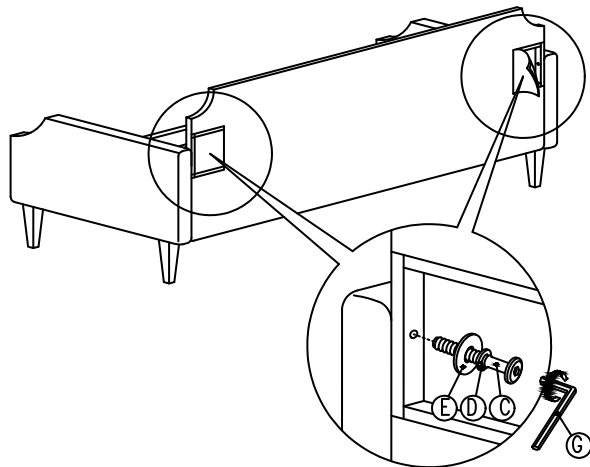

STEP 2

Attach the front rail (4) and back panel (1) to the right arm (2) and left arm (3). Aligning the holes and securing with 2 Allen Bolts (A) per each end by using L-key (H).
(DO NOT FULLY TIGHTEN BOLTS FOR THIS STEP)

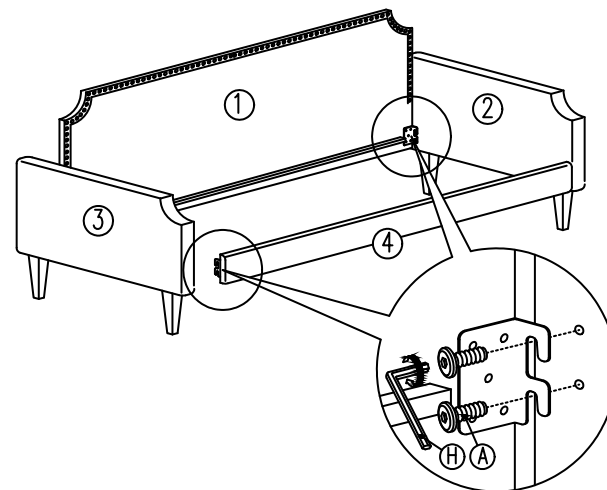

STEP 4

Tighten all Bolts on step 2 by using the L-key (H) following step 3 using L-key (G) that has been provided. Attach slats (6) to front rail (4) and back panel (1) by unrolling and securing with 2 screws (F) per each side.
Tighten all screws using philips head screwdriver (NOT INCLUDED)

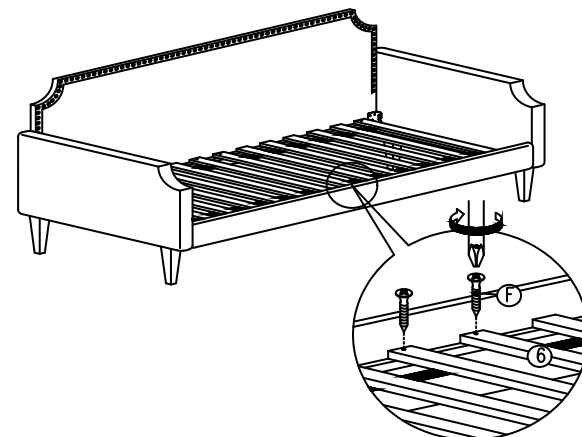

ASSEMBLY
COMPLETED