





Assembly Instructions

RECT ACACIA VNR FIXTOP TRES.BASE TABLE

HARDWARE PART:

			
JCBB Bolt 8 Pcs	Lock Washer 8 Pcs	Flat Washer 8 Pcs	Allen Key 1 Pc

ASSEMBLY:

STEP 1

Attach the leg stretcher to the Table Legs Base by inserting the wood dowel into the pre-drilled holes on the Table Legs Base. Attach **Flat Washer**, **Lock Washer** and **JCBB Bolt** by using **Allen Key** provided, but do not fully tighten until the whole base assembly is attached to the table top.

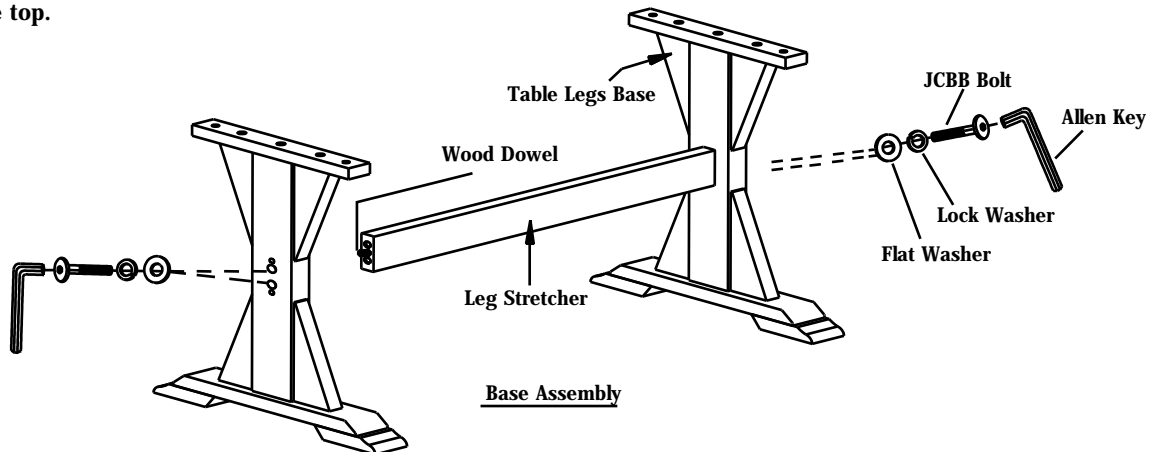

STEP 2

Place the table top upside down on a protective surface such as carpet. Align and Attach Base Assembly to the table top. Insert **Lock Washer**, **Flat Washer** and **JCBB Bolt** through the pre-drilled hole of the mounting plate into the pre-drilled hole of the Base Assembly. Then tighten the bolts by using **Allen Key** provided.

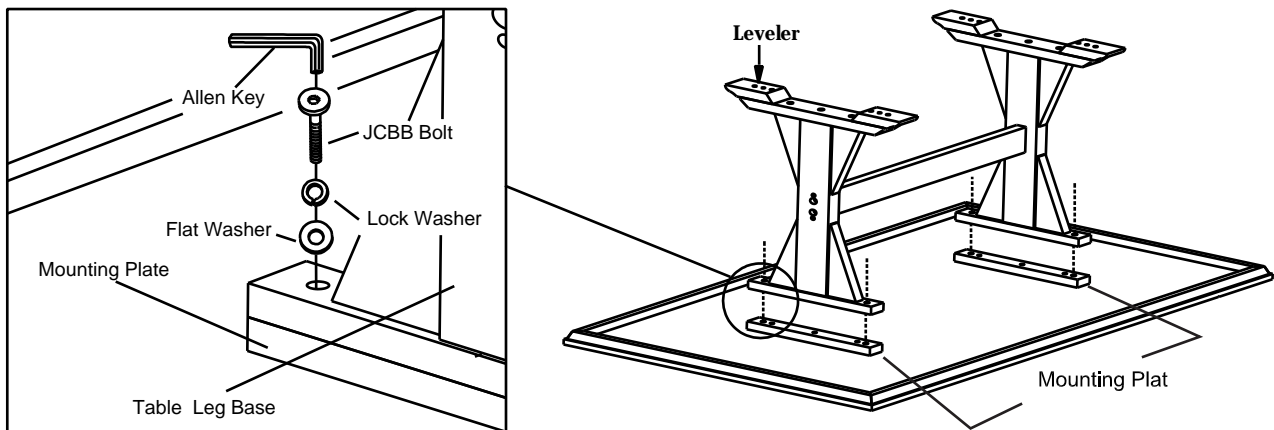

STEP 3

Set the Table upright on its legs. Check it balance and tighten all the bolts. Then Attach Cover Piece to the leg as shown.

