

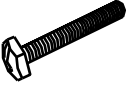







Assembly Instructions

ACACIA VENEER EXTENSION TOP LEG TABLE

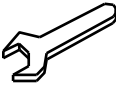
HARDWARE PARTS :

								
Hex Bolt 8 pcs	Hex Nut 8 pcs	(Large) Lock Washer 16 pcs	(Large) Flat Washer 16 pcs	Wrench 1 pce	JCBC Bolt 8 pcs	(Small) Lock Washer 8 pcs	(Small) Flat Washer 8 pcs	Allen Key 1 pce

NOTE : The unit should be assembled by 2 or more people.

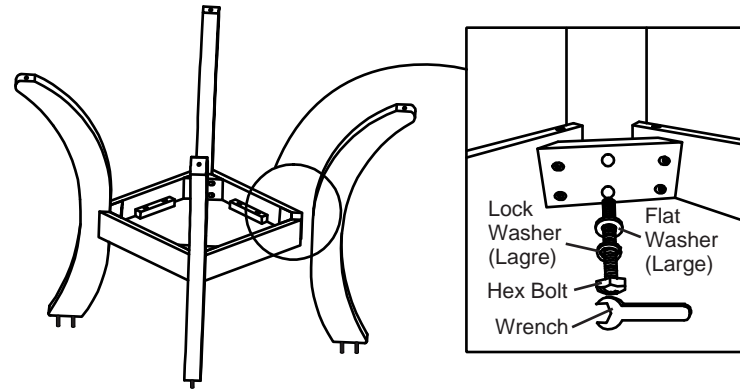

STEP 1

Place leg to the shelf panel and use **Hex Bolt**, **Lock Washer (Large)**, **Flat Washer (Large)** and **Wrench** to tighten each leg.
(Do not fully tighten yet.)

STEP 2

Attach the mounting plate onto the leg by inserting the **Hex Nut** through **Lock Washer (Large)**, **Flat Washer (Large)** then tighten the bolts with the **Wrench** provided.
(Fully tighten all Hex Nut.)

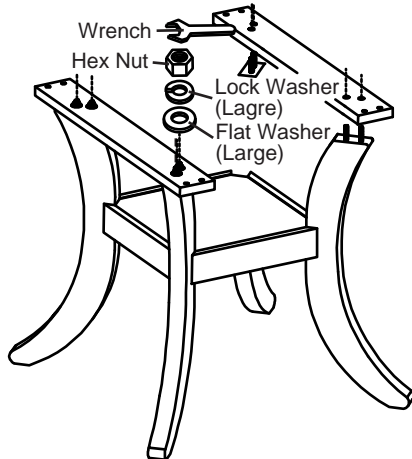

STEP 3

Position the table top upside down on a smooth and protective surface such as carpet. Attach and align the Leg Assembly as shown. Then secure with **Flat Washer (Small)**, **Lock Washer (Small)** and **JCBC Bolt**. Tighten all **Hex Bolt** and **JCBC Bolts**.

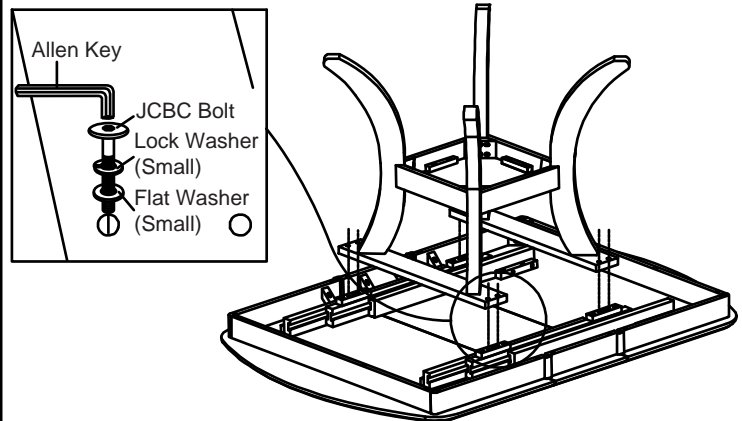

STEP 4

Unlock the cam lock underneath the table and pull the table top wide open equally from both end. Remove the center leaf as shown.

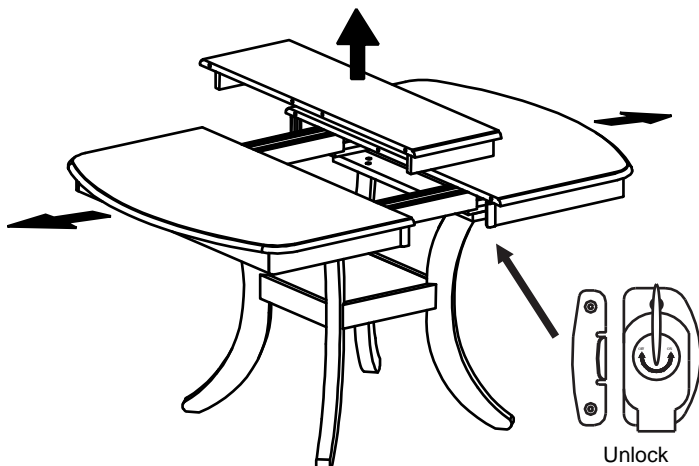

STEP 5

Push table top from both ends to close. Lock the cam lock underneath the table.

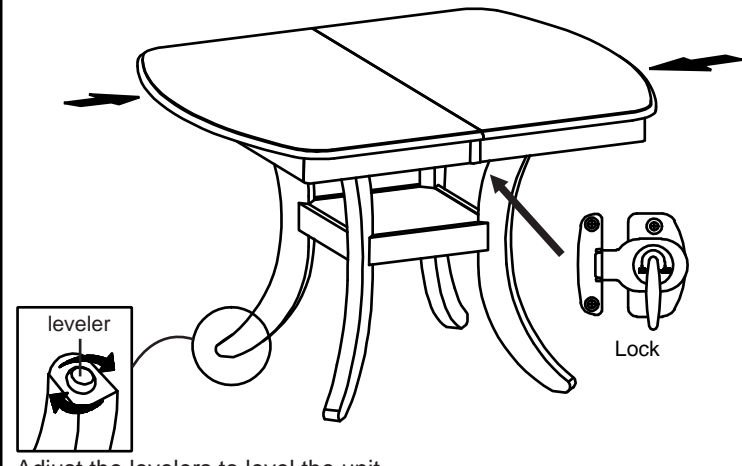

Adjust the levelers to level the unit.