









Assembly Instructions

ACACIA FIXTOP SERVER

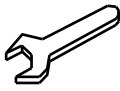
HARDWARE PARTS :

								
Hex Bolt 8 pcs	Hex Nut 4 pcs	(Large) Lock Washer 12 pcs	(Large) Flat Washer 12 pcs	Wrench 1 pce	JCBC Bolt 8 pcs	(Small) Lock Washer 8 pcs	(Small) Flat Washer 8 pcs	Allen Key 1 pce

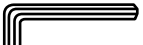
NOTE : The unit should be assembled by 2 or more people.

ASSEMBLY :

STEP 1

Pull out the Drawer Box as shown then install the legs to the corner of storage box and tighten the **Flat Washer (Large)**, **Lock Washer (Large)** and **Hex Bolt** using the **Wrench** provided. Repeat the same for the other legs.

(Do not fully tighten all the bolts yet.)

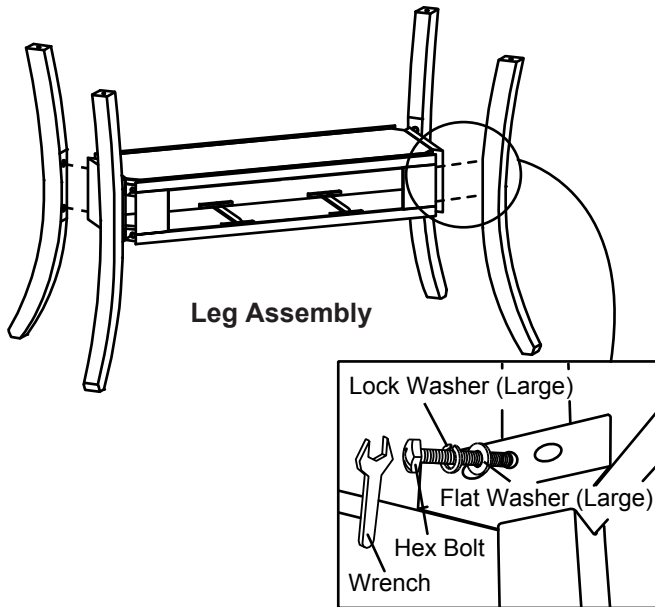

STEP 2

Attach the mounting plate onto the leg by inserting the **Hex Nut**, **Lock Washer (Large)**, **Flat Washer (Large)** then tighten the **Hex Nut** with the **Wrench** provided.

(Fully tighten all Hex Nut.)

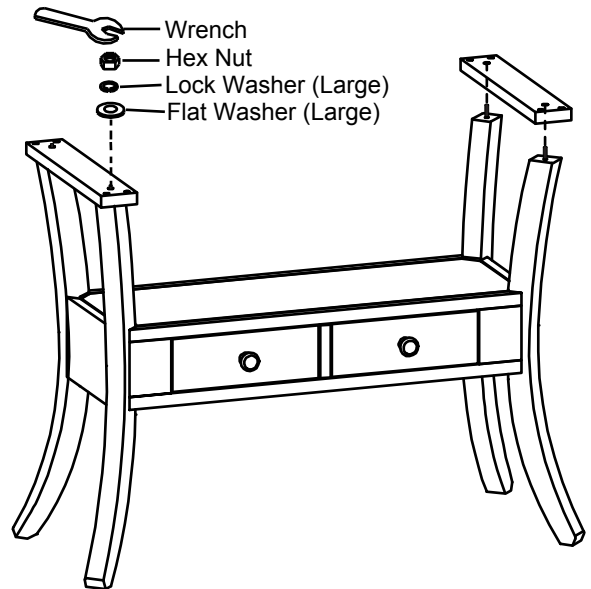

STEP 3

Position the top upside down on a smooth and protective surface such as carpet. Attach and align the Leg Assembly onto the top as shown. Then secure with **Flat Washer (Small)**, **Lock Washer (Small)** and **JCBC Bolt**. Tighten all **Hex Bolt** and **JCBC Bolts**.

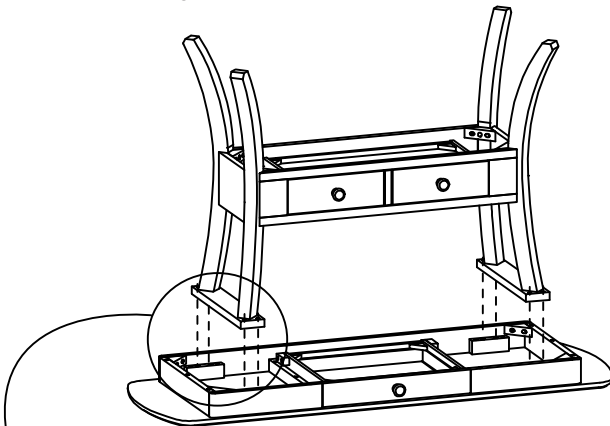

STEP 4

Turn the server upright. Check its balance and tighten all hex nut and bolts to complete the assembly.

