





ASSEMBLY INSTRUCTIONS

MODEL : EASTON BENCH

IMPORTANT NOTE :

- * PLACE ALL WOODEN PARTS ON A CLEAN AND SMOOTH SURFACE SUCH AS A RUG OR CARPET TO AVOID THE PARTS FROM BEING SCRATCHED.
- * BEFORE YOU BEGIN, KINDLY FOLLOW THE ASSEMBLY INSTRUCTIONS STEP BY STEP.

HARDWARE LIST

A	HEX NUT 5/16"		8PCS
B	SPRING WASHER 5/16"		8PCS
C	FLAT WASHER 5/16"		8PCS
D	SPANNER 12.8		1PC

PART LIST

1	BENCH TOP	1PC
2	BENCH LEG	4PCS

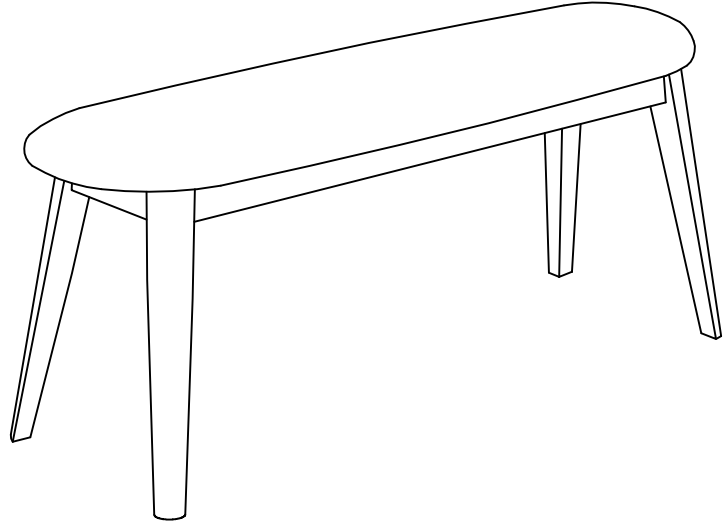

COMPLETED BENCH ASSEMBLY.

INSTRUCTION :-

(STEP 1)

Place Bench Top (1) face down on a clean and flat surface to prevent from being scratched.

(STEP 2)

Position Bench Leg (2) with Hanger Bolt facing to Corner Block holes of Bench Frame , then insert Flat Washer (C) with Spring Washer (B) and Hex Nut (A) then tighten with Spanner (D) provided.

(STEP 3)

Repeat Step 2 for other 3 legs assembly.

(STEP 4)

Revert the Bench for completion of Bench assembly.

