

ASSEMBLY INSTRUCTIONS

MODEL : CH 6

IMPORTANT NOTE :

- * PLACE ALL WOODEN PARTS ON A CLEAN AND SMOOTH SURFACE SUCH AS A RUG OR CARPET TO AVOID THE PARTS FROM BEING SCRATCHED.
- * BEFORE YOU BEGIN, KINDLY FOLLOW THE ASSEMBLY INSTRUCTIONS STEP BY STEP.
- * DO NOT TIGHTEN ALL SCREWS UNTIL THE CHAIR IS FULLY SET-UP

HARDWARE LIST

A	JCBC BOLT (LONG)		4 PCS
B	JCBC BOLT (MEDIUM)		4 PCS
C	JCBC BOLT (SHORT)		2 PCS
D	FLAT WASHER		10 PCS
E	SPRING WASHER		10 PCS
F	WOOD SCREW		6 PCS
G	ALLEN KEY		1 PC

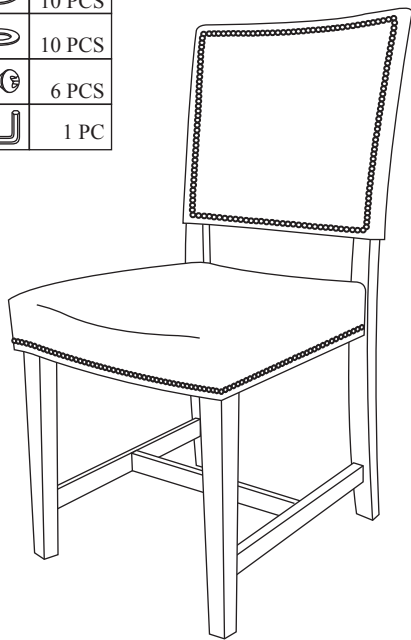

Fully Set-up

STEP 1

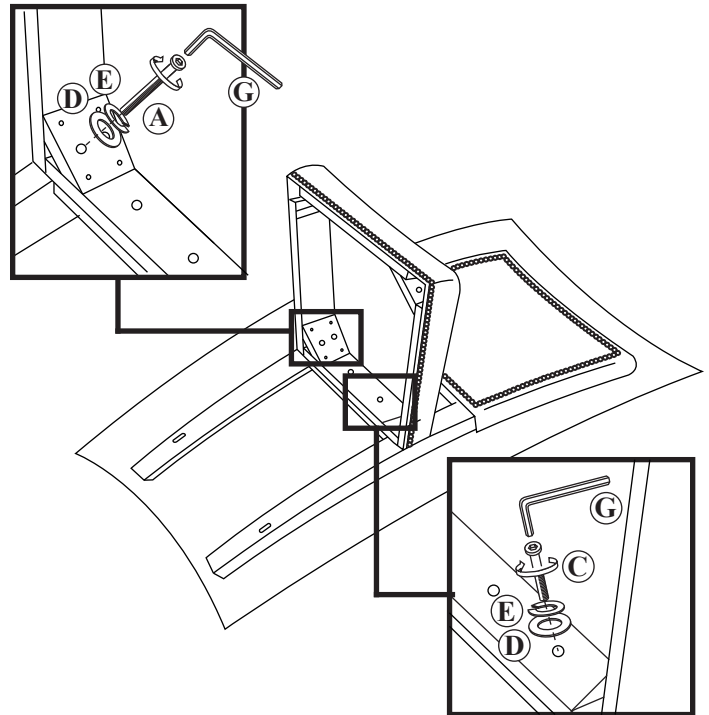

STEP 2

- * REMARK : STRETCHER WITH A SMALL HOLE IS TO BE ASSEMBLE WITH CHAIR BACK
- * THE LOWER HOLE FOR THE FRONT LEG SHOULD BE USED FOR THE FRONT BAR & THE HIGHER HOLE SHOULD BE USED FOR THE SIDE BARS

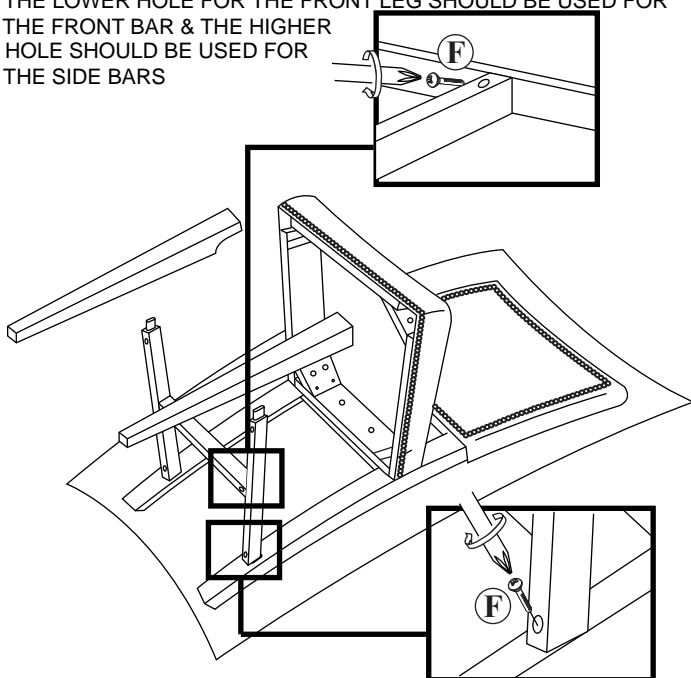

STEP 3

