









ITEM NO:C1860D PUB TABLE

NO.	QTY	DRAWING	DESCRIPTION
A	1		TABLE TOP
B	1		STRETCHER
C	4		LEG
D	8		1/4X12mm
E	4		1/4X20mm
F	8		SPRING WASHING
H	8		FLAT WALEN
I	1		4mm/ALLENKEY

Note:Pls do not tighten all bolts until the table is assembled completely.Once assembled,tighten all bolts before attaching the table.

Note: Pls ne pas serrer tous les boulons jusqu'à ce que la table est assemblé completely.Once assemblé, serrer tous les boulons avant de fixer la table.

Step1

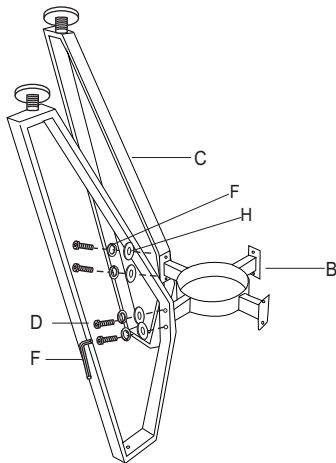

Step2

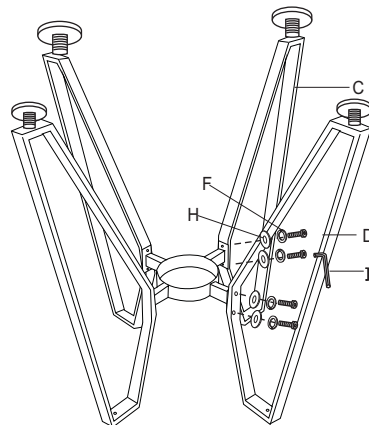

Step3

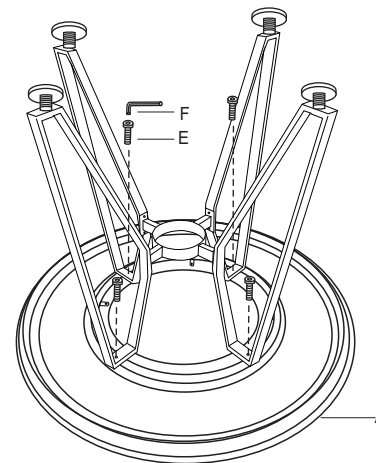





Step4



TO TOUCH HIT FOR LOUE

ITEM NO:C1860P PUB CHAIR

NO.	PART	DESC	DESCRIPTION
A		SEAT	1PC
B		LEG	1PC
C		BOLT 1/4X25mm	4PC
D		FLAT WALEN	4PC
E		ALLENKEY	1PC

Note:Pls do not tighten all bolts until the chair is assembled completely.Once assembled,tighten all bolts before attaching the chair.

Note: Pls ne pas serrer tous les boulons jusqu'à ce que les selles est completely.Once assemblé assemblé, serrer tous boulons avant de fixer les selles.

Step1

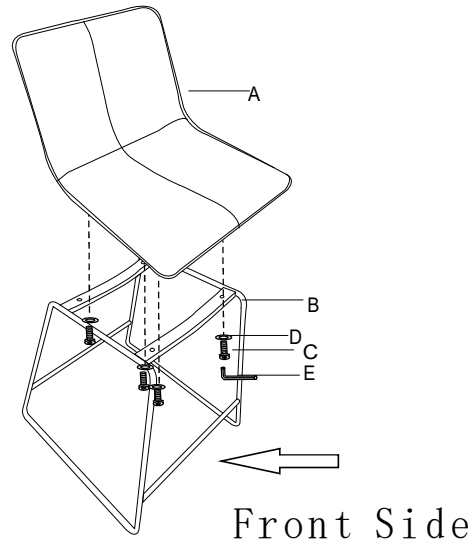

Step2

