

ASSEMBLY INSTRUCTION

MODEL : Benjamin Twin

NO	PART LIST	QTY
1	HEAD BOARD CUSHION	1pc
2	HEAD BOARD LEG	2pcs
3	FOOT BOARD CUSHION	1pc
4	FOOT BOARD LEG	2pcs
5	SIDE RAIL (left)	2pcs
6	SIDE RAIL (right)	2pcs
7	SIDE RAIL SUPPORT	2pcs
8	SLAT	4pcs
9	SLAT SUPPORT (with adjustable feet)	4pcs
NO	HARDWARE LIST	QTY
A	JCBB SCREW M8 x 20mm	8pcs
B	JCBC SCREW M6 x 25mm	8pcs
C	JCBC SCREW M6 x 35mm	10pcs
D	JCBC SCREW M6 x 70mm	2pcs
E	SPRING WASHER	14pcs
F	FLAT WASHER	14pcs
G	SCREW M4 x 32mm	8pcs
H	DOWEL	2pcs
I	L - KEY M5 x 65mm	1pc
J	L - KEY M4 x 100mm	1pc

STEP 1 Begin assembly by attaching each Head Board Leg (2) to the bottom of the Head Board Cushion (1) by aligning the hole and securing with 3 Allen Bolt (C), 3 Spring Washer (E), 3 Flat Washer (F) per leg. (DO NOT FULLY TIGHTEN BOLTS FOR THIS STEP)

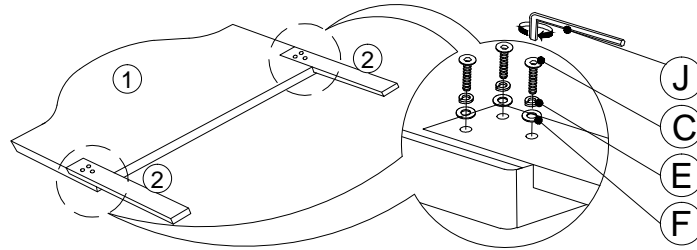

STEP 2 Attach each Foot Board Leg (4) to the bottom of the Foot Board Cushion (3) securing with 1 Allen Bolt (D), 1 Dowel (H) per leg.

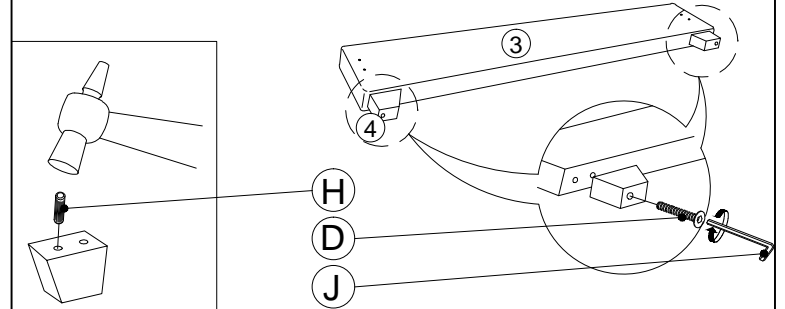

STEP 3 Attach Side Rail Support (7) to the join of the Side Rail Left (5) and Side Rail Right (6) securing with 4 Allen Bolt (B), 4 Spring Washer (E), 4 Flat Washer (F) per support. (TIGHTEN BOLTS FOR THIS STEP)

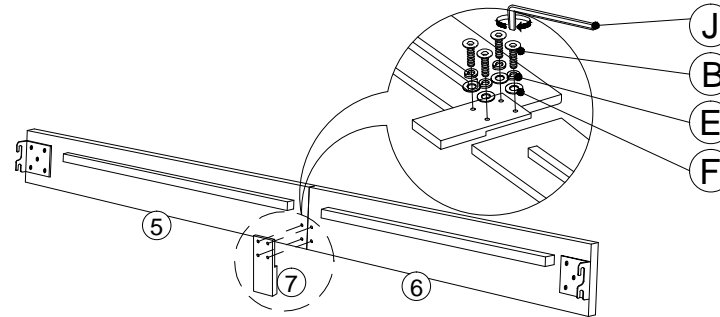

STEP 4 Attach the Side Rail to the Head Board and Foot Board. Aligning holes and securing with 2 Allen Bolts (B) per each end. (DO NOT FULLY TIGHTEN BOLTS FOR THIS STEP)

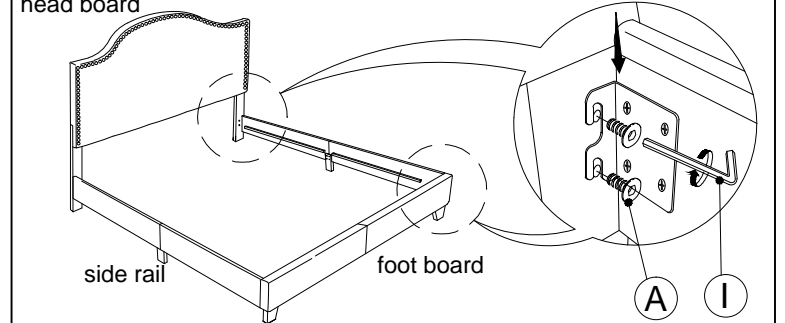

STEP 5 Attach Slat Support (9) to Slat (8). Securing with 1 Allen Bolt (C) per support. Attach Slat (8) to Side Rail. Securing with 1 Wood Screws (G) per each side. Tighten all screws using philips head screwdriver (not included). Tighten all bolts on STEP 2 using the Allen Wrench (J) following STEP 4 using the Allen Wrench (I) that has been provided.

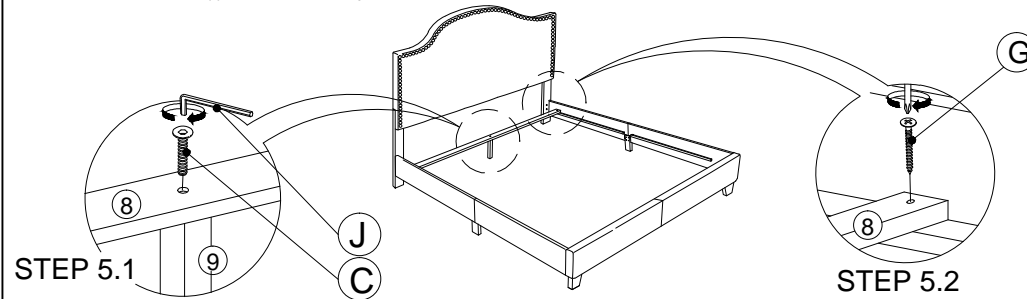

Your new Benjamin Bed is now complete

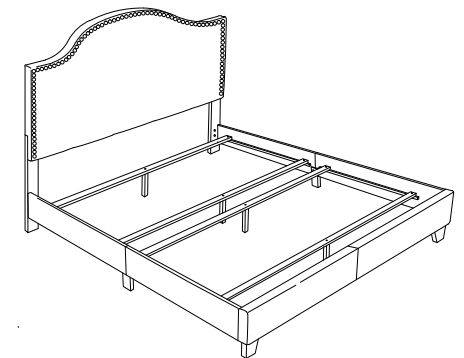

NOTE: AFTER A FEW DAYS OF ASSEMBLY, IT WILL HAVE ACCLIMATIZED TO THE ENVIRONMENT. PLEASE TIGHTEN ALL HARDWARE. CHECK TIGHTNESS OF ALL SCREWS EVERY 6-8 WEEKS.

01-JAN-16

PG : 1 / 1