

Read this instruction carefully. See hardware and furniture part list for guidance. Be sure all parts are complete, before you assemble. Place all wooden furniture parts on a clean and flat soft surface to prevent from being scratched. Follow the figure to start assembling.

**CAUTIONS :** 1. Do not FULLY - TIGHTEN the nut or nut bolt until all nut or bolt is ready assembled.  
 2. Do not OVER - TIGHTEN the nut or bolt to avoid causing damages to the thread.  
 3. Keep all hardware parts out of reach of children.

**NOTE :** THE LIST AND QUANTITY SHOWN ARE FOR 1 UNIT ASSEMBLY.  
 Tool needed : Screwdriver (not provider).

HARDWARE LIST		
ITEM	DESCRIPTION	QTY
A	BACK	1 PC
B	CUSHION SEAT	1 PC
C	ARM	2 PCS
D	STRETCHER	2 PCS
E	BACK STRETCHER	1 PC
F	SIDE STRETCHER	5 PCS
G	CENTER SUPPORT LEG	1 PC

HARDWARE LIST		
ITEM	DESCRIPTION	QTY
1	JCBC Bolt M6 x 65mm	6 PCS
2	JCBB Bolt M8 x 60mm	4 PCS
3	WOOD SCREW M4 x 38mm	22 PCS
4	M8 FLAT WASHER	4 PCS
5	M8 SPRING WASHER	4 PCS
6	WOOD DOWEL M10 x 40mm	26 PCS
7	BARREL NUT M6 x 10 x 13mm (ZB)	6 PCS
8	WOOD BUTTON DIA 14.5 x 9mm	8 PCS
9	M4 ALLEN KEY (BALL SHAPE)	1 PC
10	M5 ALLEN KEY (BALL SHAPE)	1 PC

## STEP 1

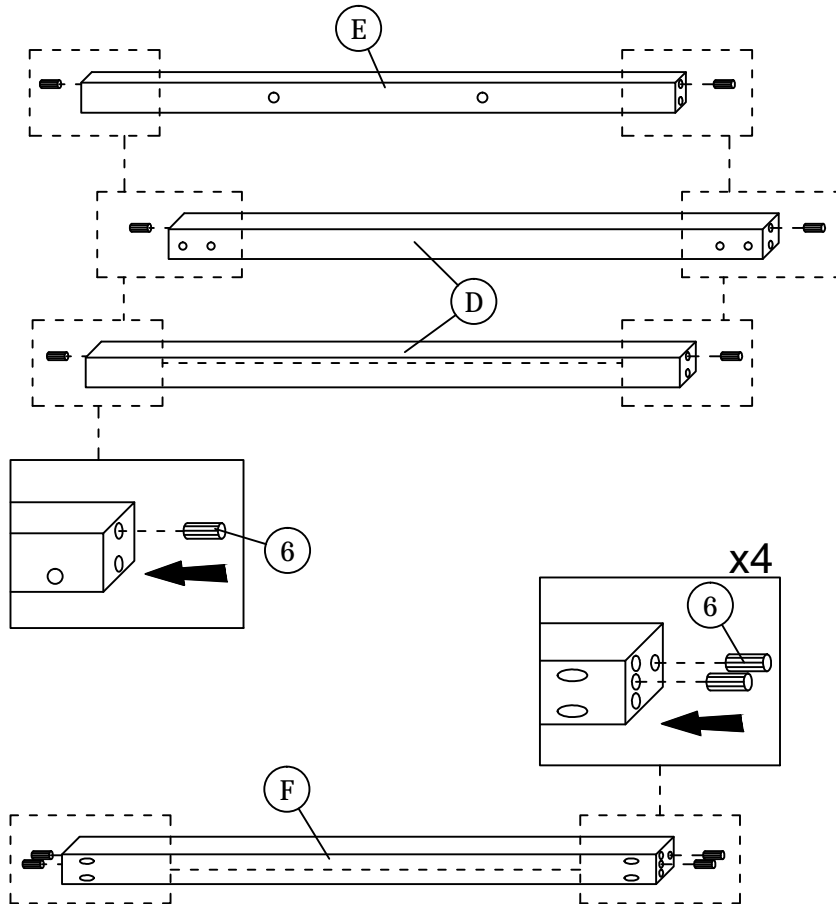

## STEP 2

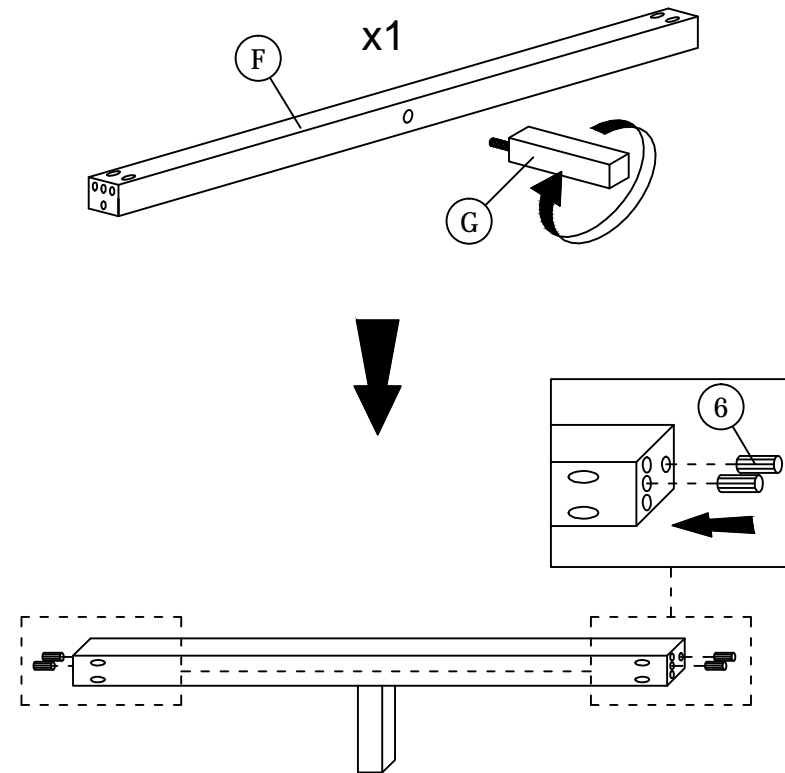

# ASSEMBLY INSTRUCTIONS

## STEP 3

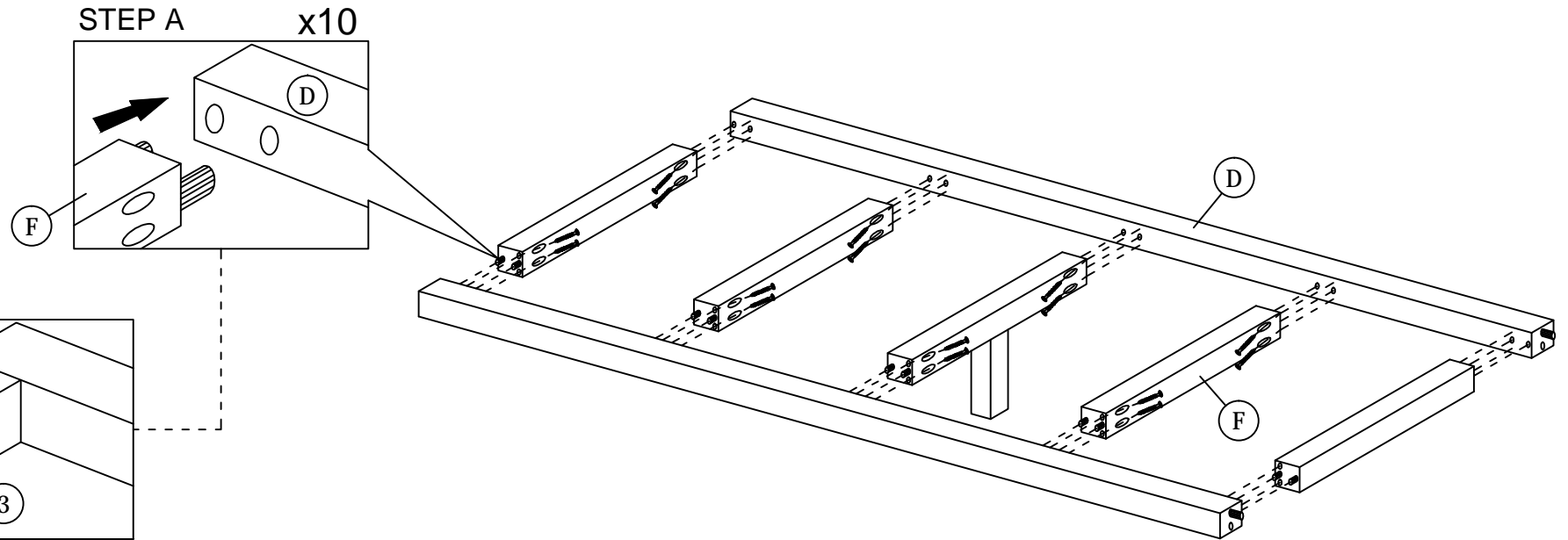

## STEP 4

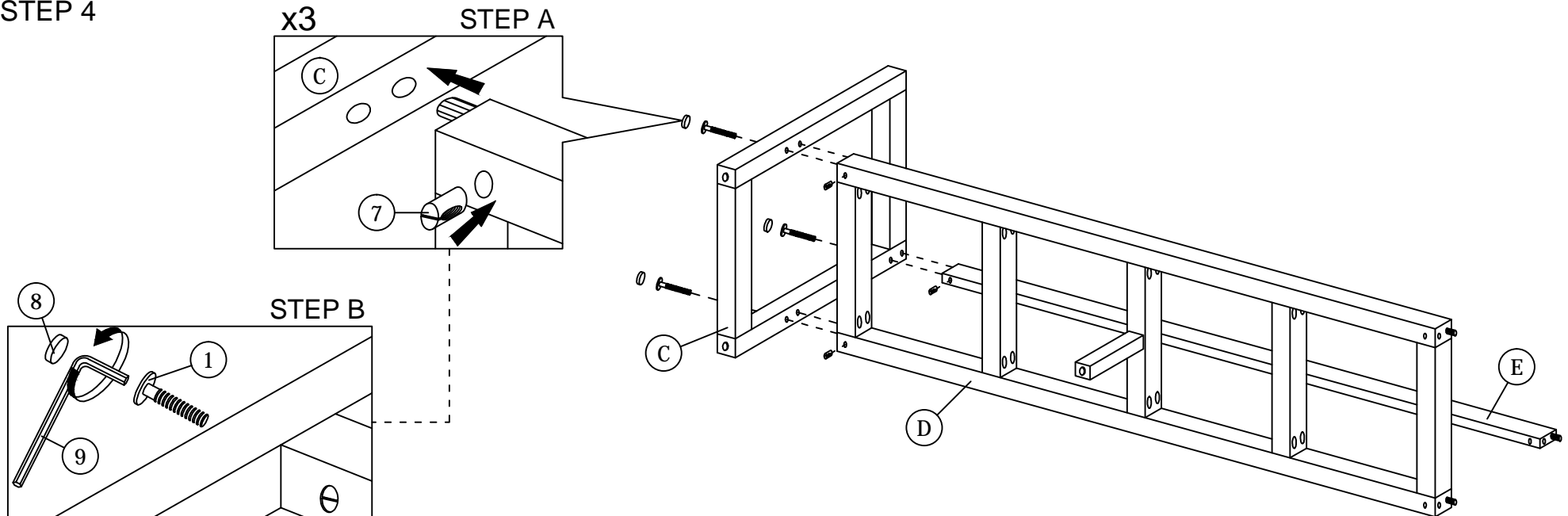

# ASSEMBLY INSTRUCTIONS

## STEP 5

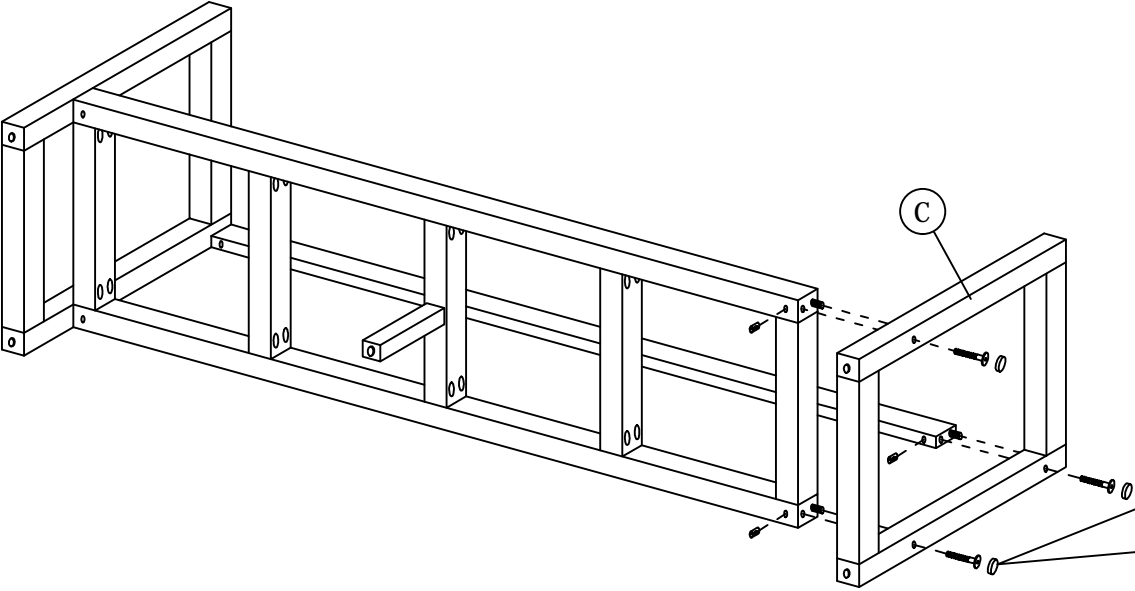

## STEP B

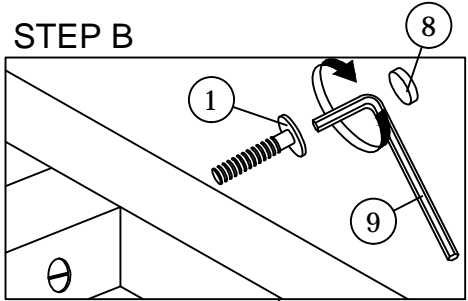

## STEP A

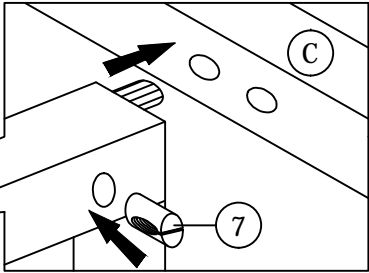

## STEP 6

x4

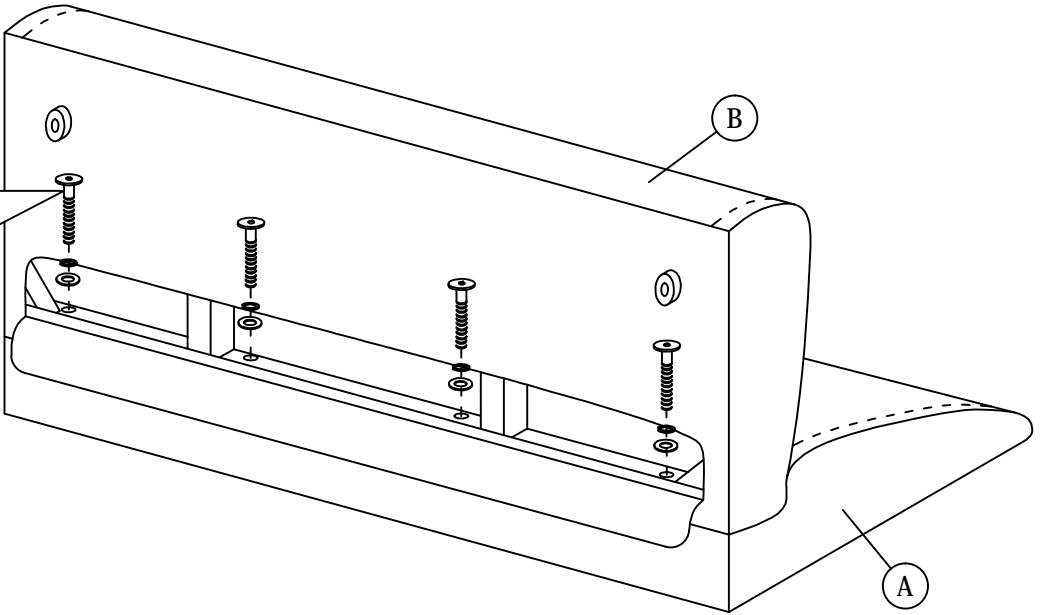
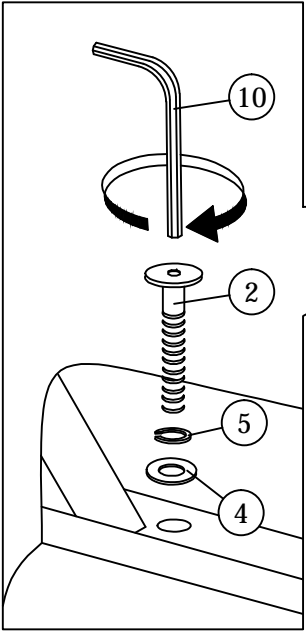

# ASSEMBLY INSTRUCTIONS

STEP 7

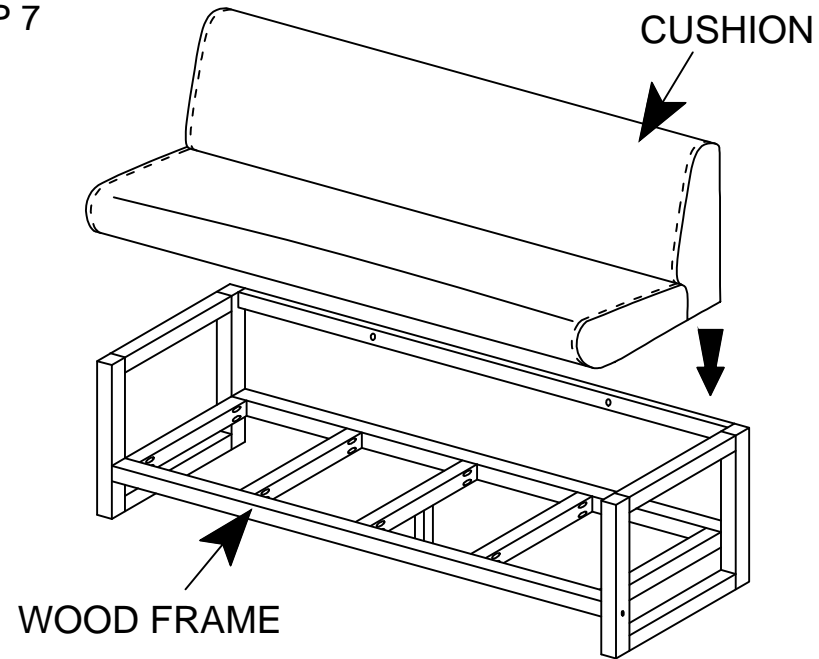

STEP 8

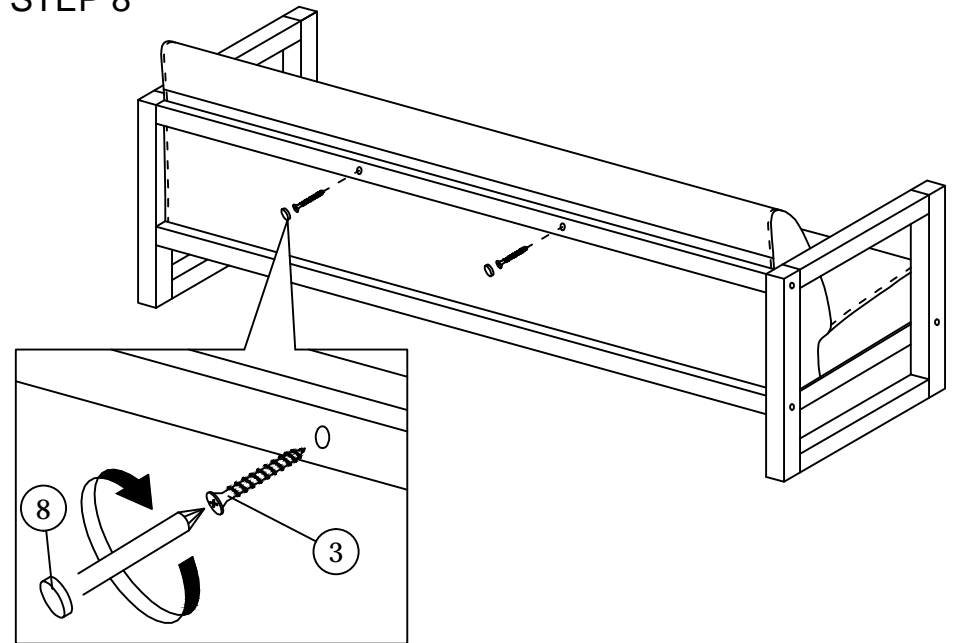

STEP 9

