

Read this instruction carefully. See hardware and furniture part list for guidance. Be sure all parts are complete, before you assemble. Place all wooden furniture parts on a clean and flat soft surface to prevent from being scratched. Follow the figure to start assembling.

CAUTIONS : 1. Do not FULLY - TIGHTEN the nut or nut bolt until all nut or bolt is ready assembled.
 2. Do not OVER - TIGHTEN the nut or bolt to avoid causing damages to the thread.
 3. Keep all hardware parts out of reach of children.

NOTE : THE LIST AND QUANTITY SHOWN ARE FOR 1 UNIT ASSEMBLY.

Tool needed : Screwdriver (not provider).

PART LIST		
ITEM	DESCRIPTION	QTY
A	HEADBOARD	1 PC
B	FOOTBOARD	1 PC
C	SIDE RAIL	2 PCS
D	CENTER RAIL	1 PC
E	CENTER SUPPORT	2 PCS
F	CENTER SUPPORT LEG	3 PCS
G	BED LEG	4 PCS
H	BED SLAT	24 PCS

HARDWARE LIST		
ITEM	DESCRIPTION	QTY
1	JCBC BOLT M6 x 20mm	8 PCS
2	M6 FLAT WASHER	8 PCS
3	M6 SPRING WASHER	8 PCS
4	WOOD SCREW M3.5 x 16mm	8 PCS
5	WOOD SCREW M4 x 20mm	2 PCS
6	BED SLAT SIDE FITTER	24 PCS
7	BED SLAT CENTER FITTER	12 PCS
8	M4 ALLEN KEY (BALL SHAPE)	1 PC
9	M5 ALLEN KEY (BALL SHAPE)	1 PC

STEP 1

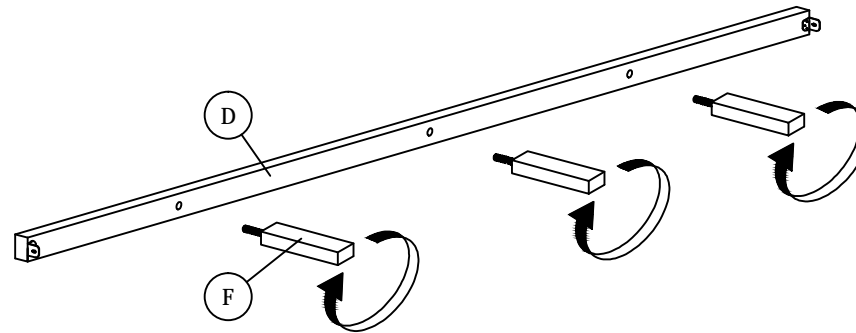

STEP 2

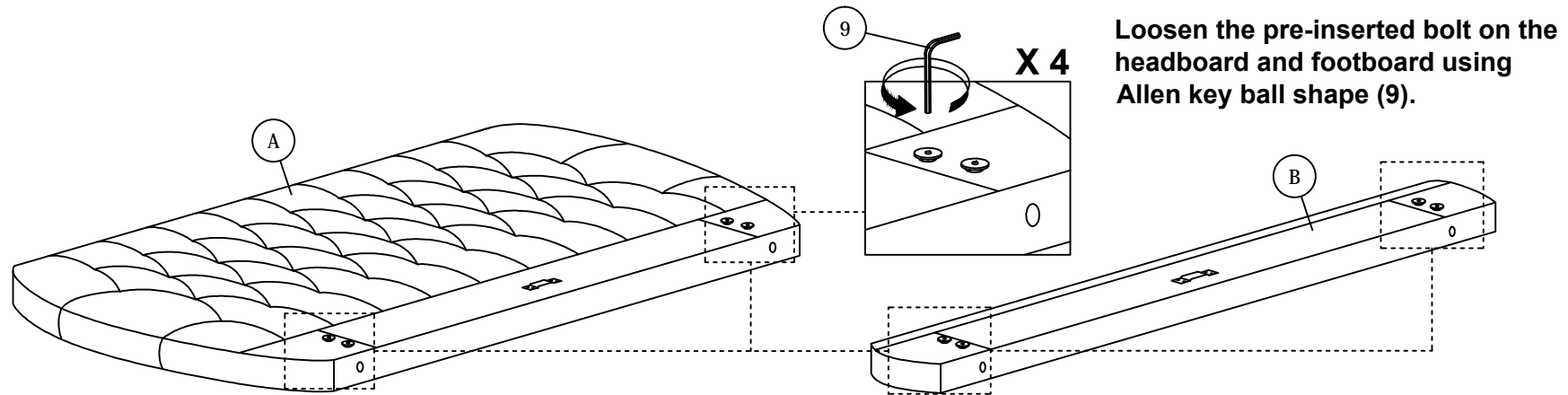

ASSEMBLY INSTRUCTIONS

STEP 3

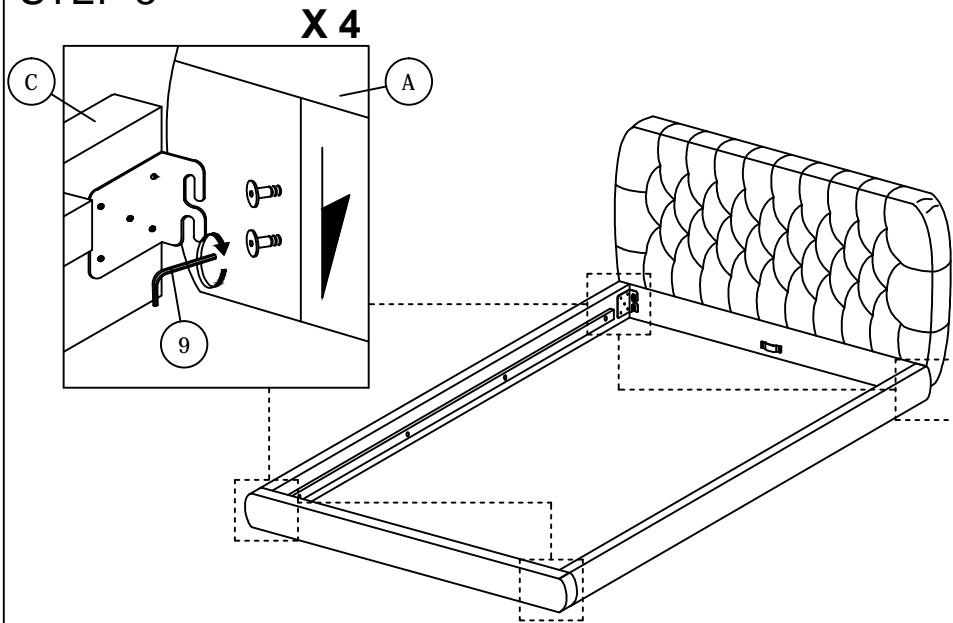

STEP 4

NOTE :
Make sure the floor is clean and smooth when put down the bed to prevent scratches.

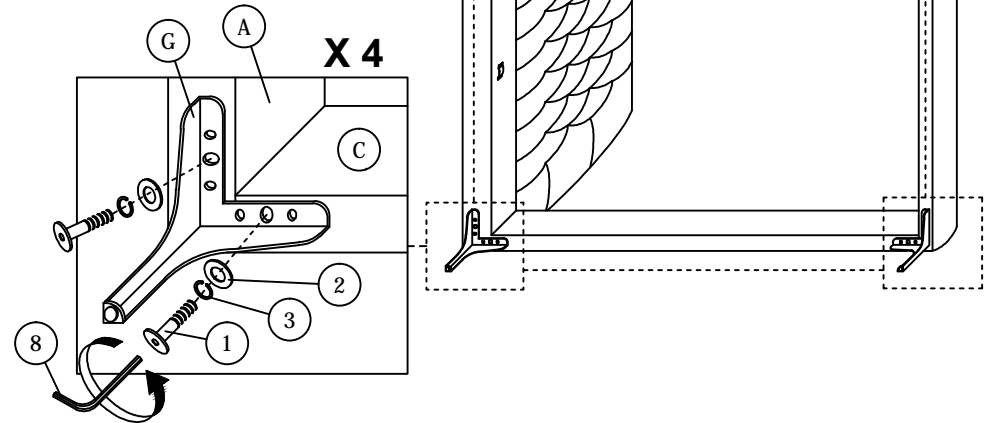

STEP 5

Note: Assemble (E) vertically as picture shown.

STEP 5.1

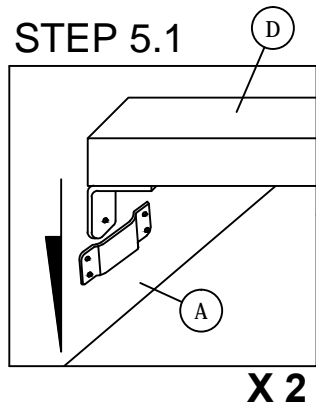

STEP 5.2

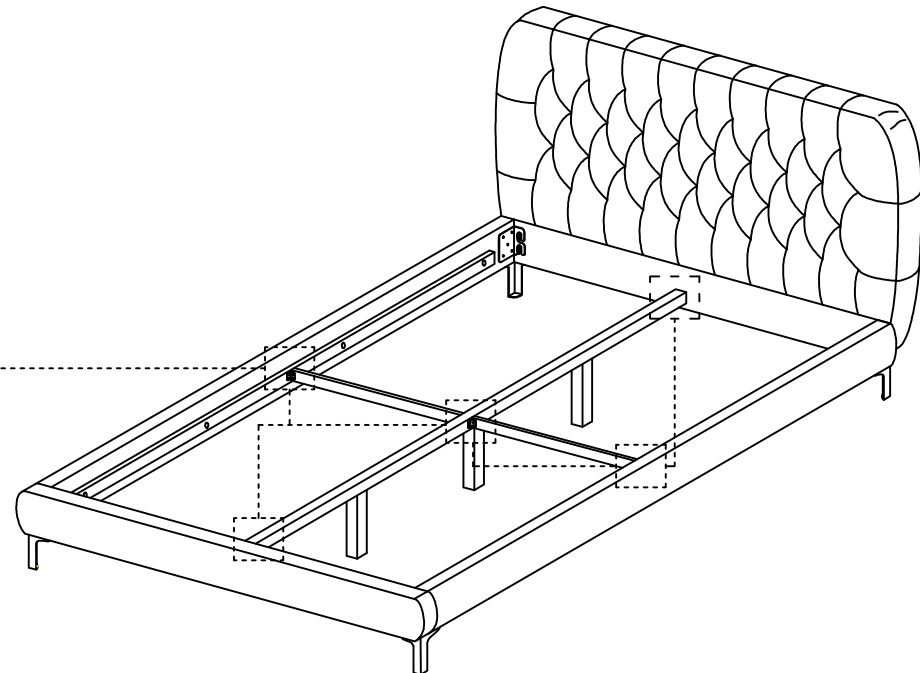
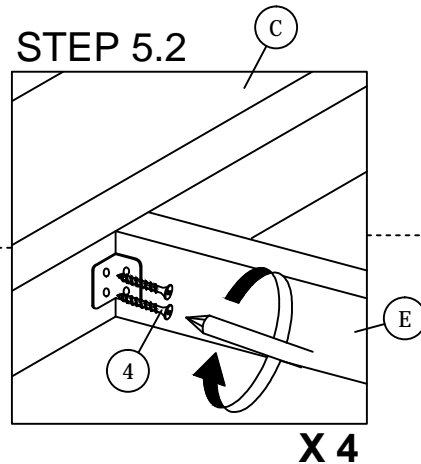

ASSEMBLY INSTRUCTIONS

STEP 6

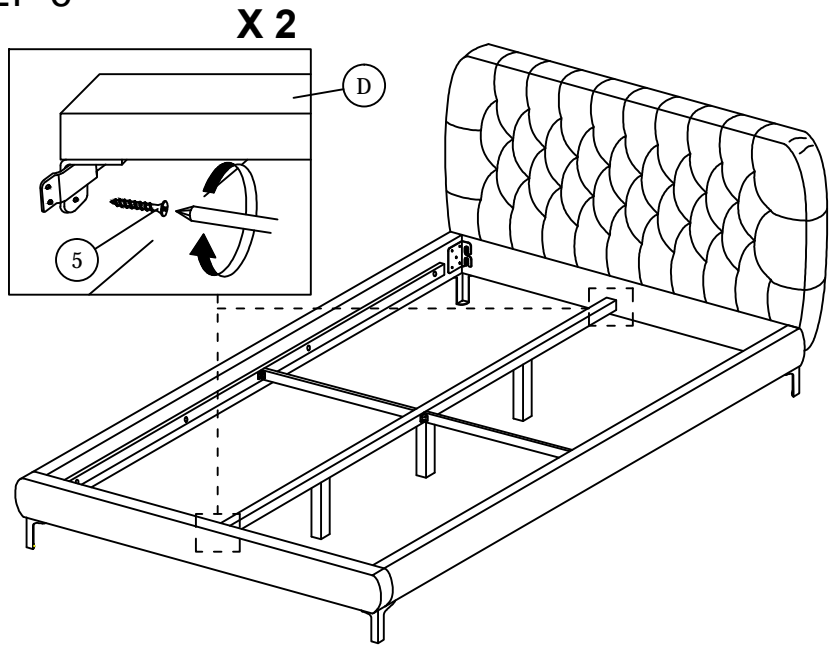

STEP 7

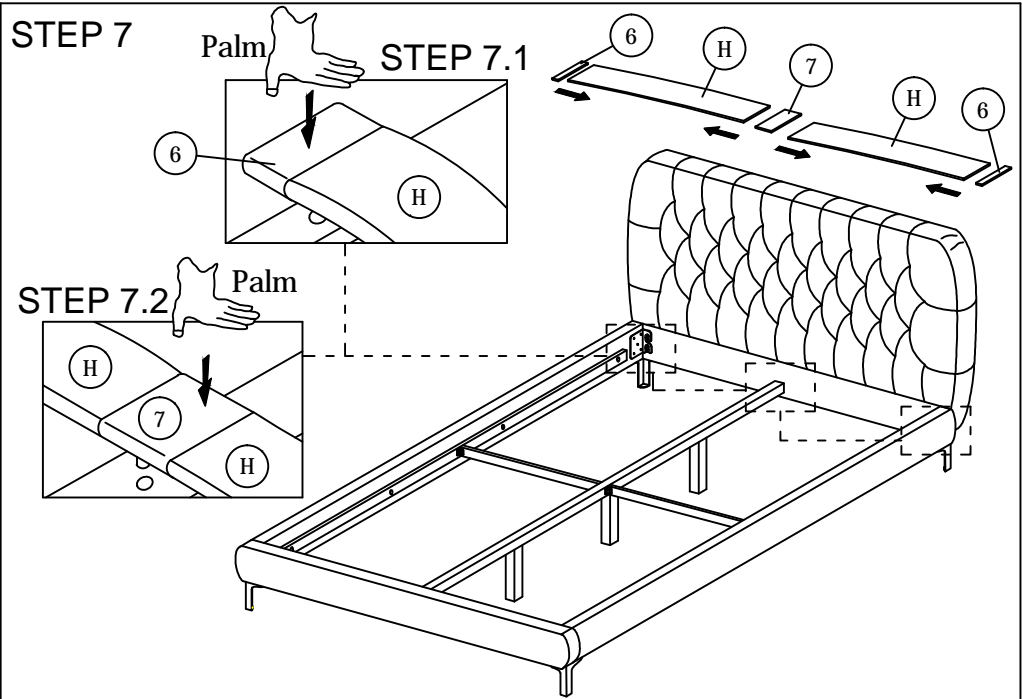

STEP 8

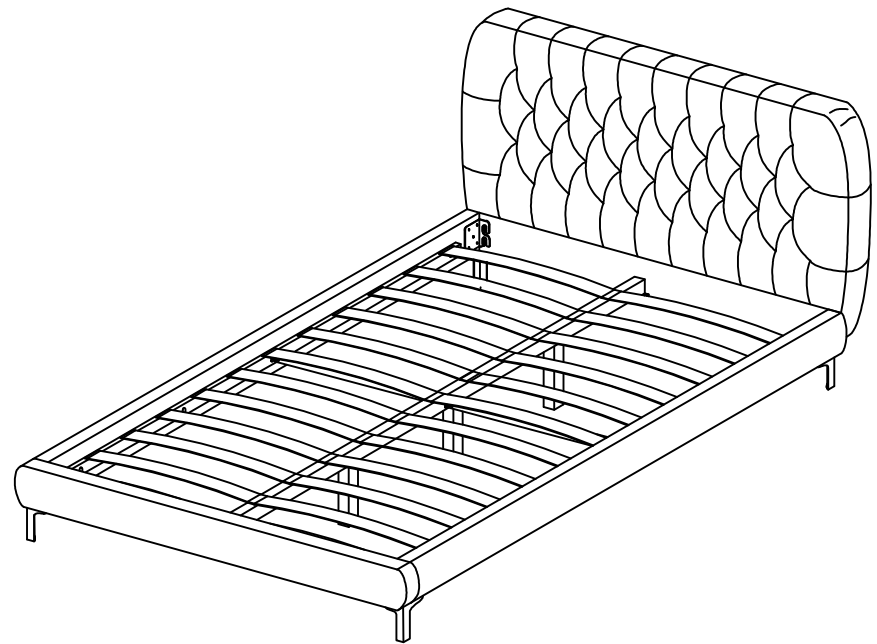

* When moving the bed position, the center support legs must be adjust to be straight to avoid any broken problem.