

Read this instruction carefully. See hardware and furniture part list for guidance. Be sure all parts are complete, before you assemble. Place all wooden furniture parts on a clean and flat soft surface to prevent from being scratched. Follow the figure to start assembling.

CAUTIONS :

1. Do not FULLY - TIGHTEN the nut or nut bolt until all nut or bolt is ready assembled.
2. Do not OVER - TIGHTEN the nut or bolt to avoid causing damages to the thread.
3. Keep all hardware parts out of reach of children.

NOTE : THE LIST AND QUANTITY SHOWN ARE FOR 1 UNIT ASSEMBLY.

Tool needed : Screwdriver & Hammer (not provider).

PART LIST		
ITEM	DESCRIPTION	QTY
A	HEADBOARD	1 PC
B	FOOTBOARD	1 PC
C	SIDE RAIL (L&R)	2 PCS
D	CENTER RAIL	1 PC
E	CENTER SUPPORT LEG	3 PCS
F	LEG	4 PCS
G	BED SLAT	1 SET
H	VMB 3032 Bracket (Size:60 x 60 x 100 x 3mm)	4 PCS

HARDWARE LIST		
ITEM	DESCRIPTION	QTY
1	JCBB BOLT M8 x 30mm	6 PCS
2	JCBB BOLT M8 x 20mm	12 PCS
3	M8 FLAT WASHER	22 PCS
4	M8 SPRING WASHER	22 PCS
5	5/16" HEX NUT	4 PCS
6	WOOD DOWEL M10 x 30mm	4 PCS
7	WOOD SCREW M4 x 38mm	9 PCS
8	SPANNER (13mm)	1 PC
9	M5 ALLEN KEY (BALL SHAPE)	1 PC

STEP 1

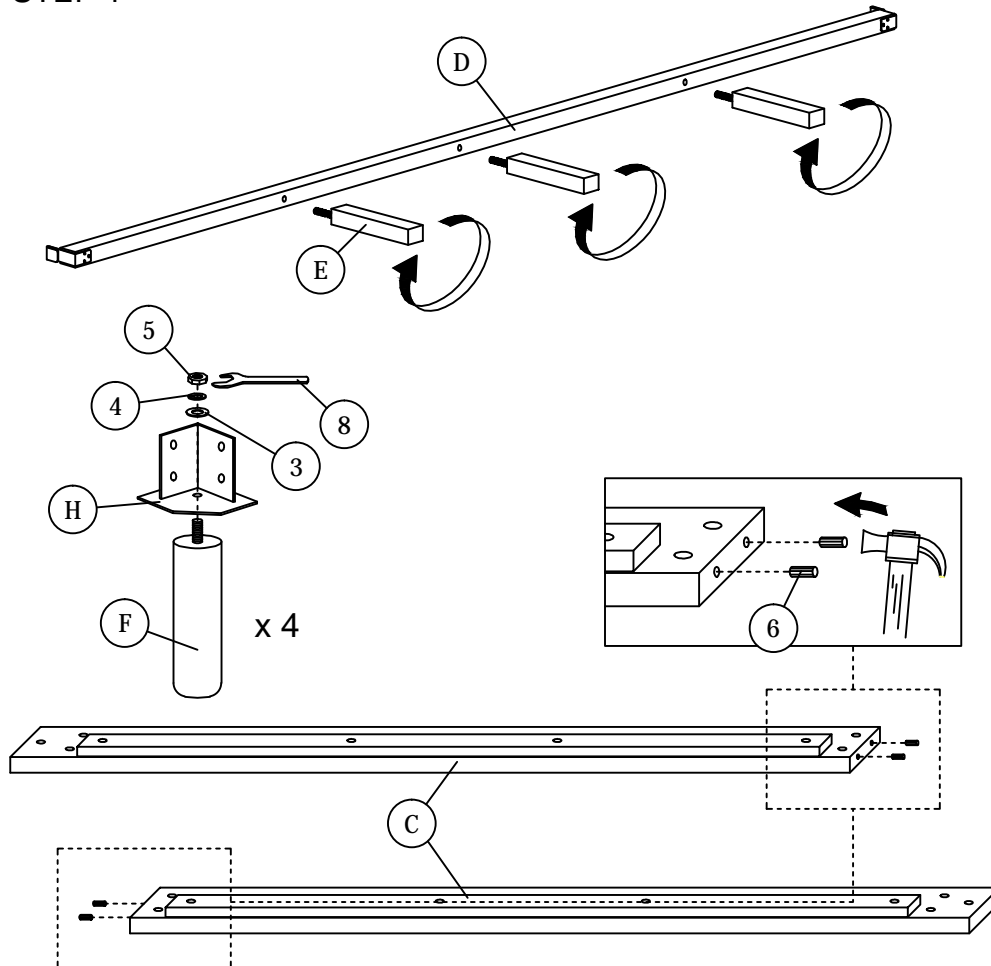

STEP 2

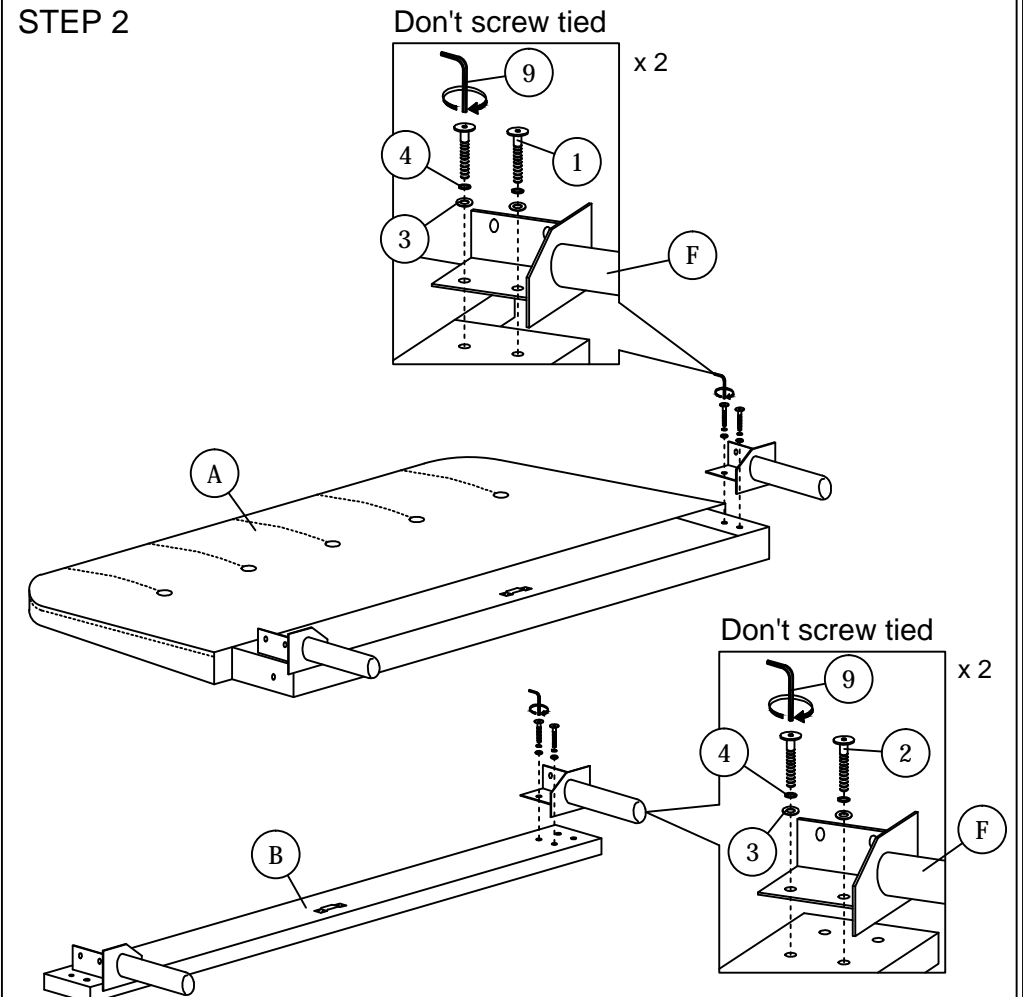

ASSEMBLY INSTRUCTIONS

STEP 3

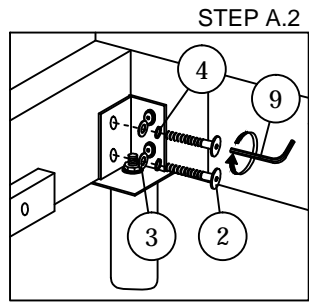

Don't screw tied

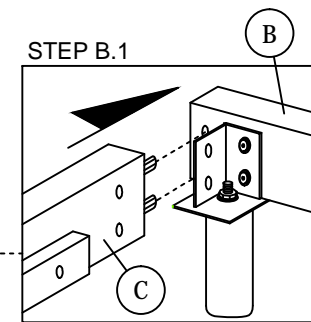
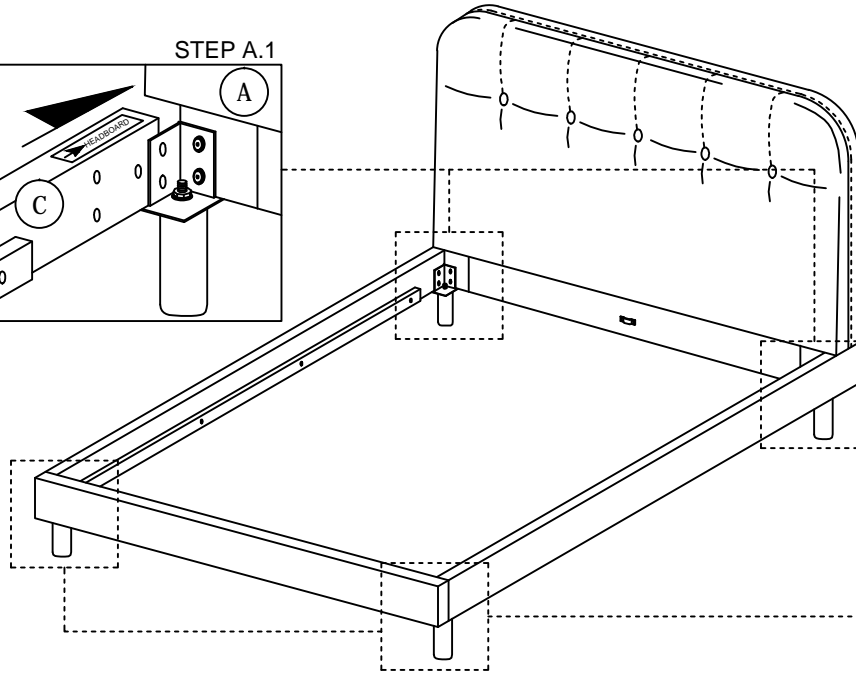
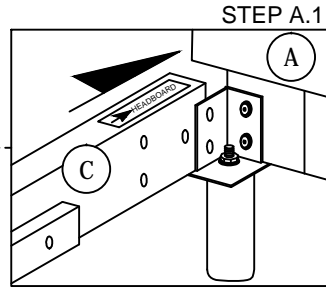

STEP B.2

Don't screw tied

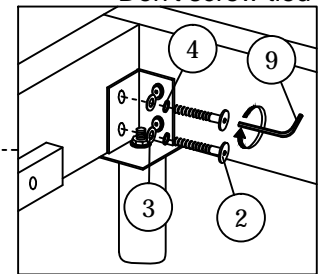

STEP 4

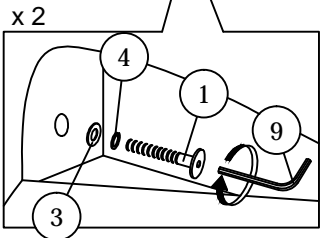
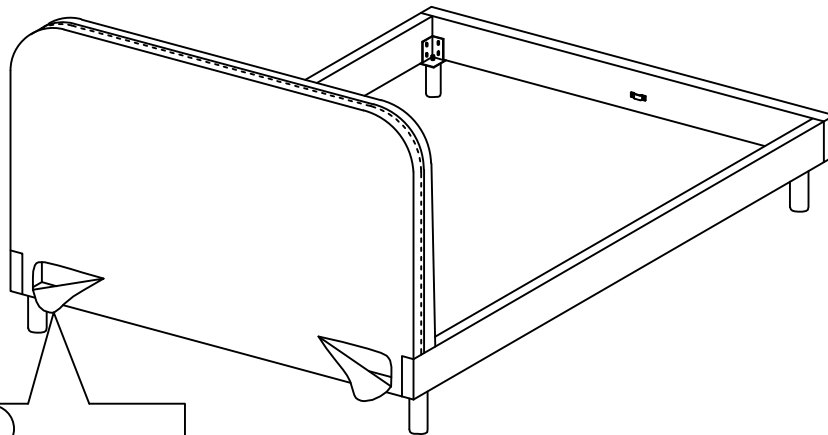

****Finish step 4,
Please screw tied the step 2 & 3 bolt.**

STEP 5

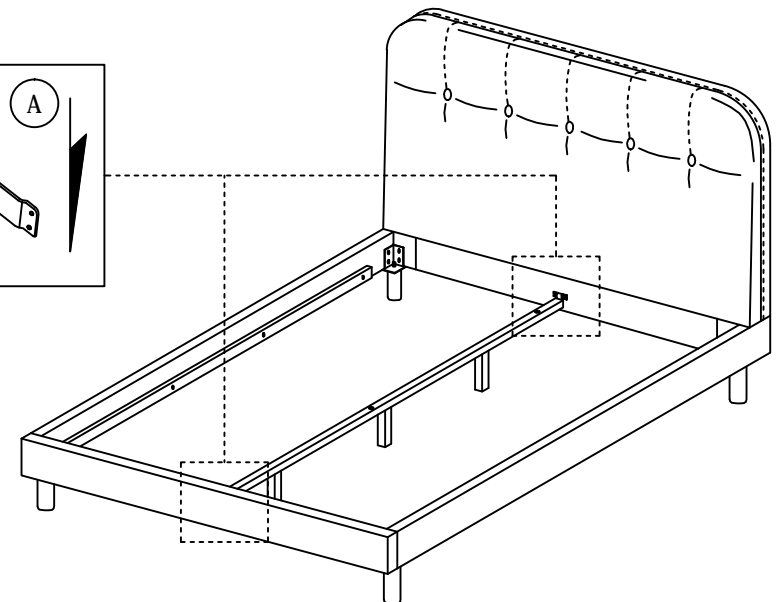
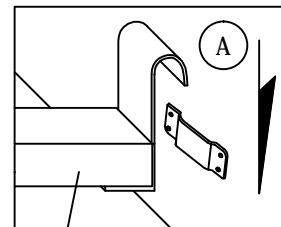

ASSEMBLY INSTRUCTIONS

STEP 6

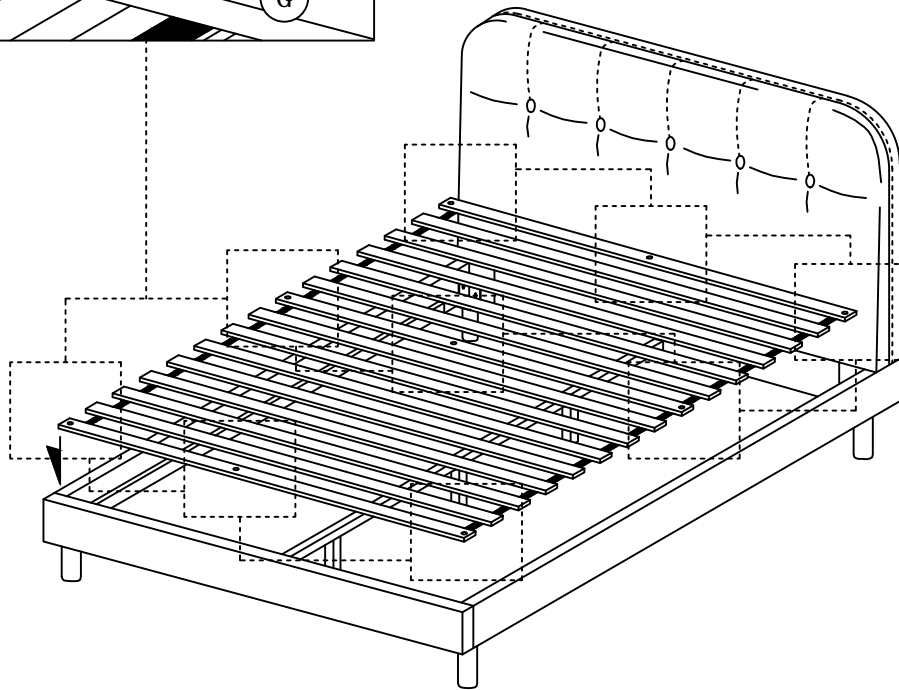
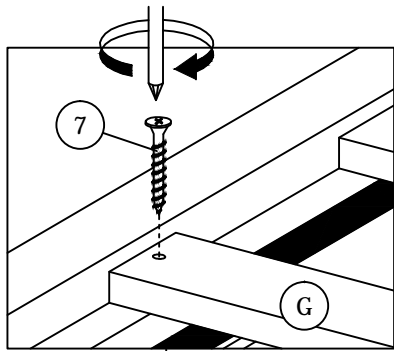

STEP 7

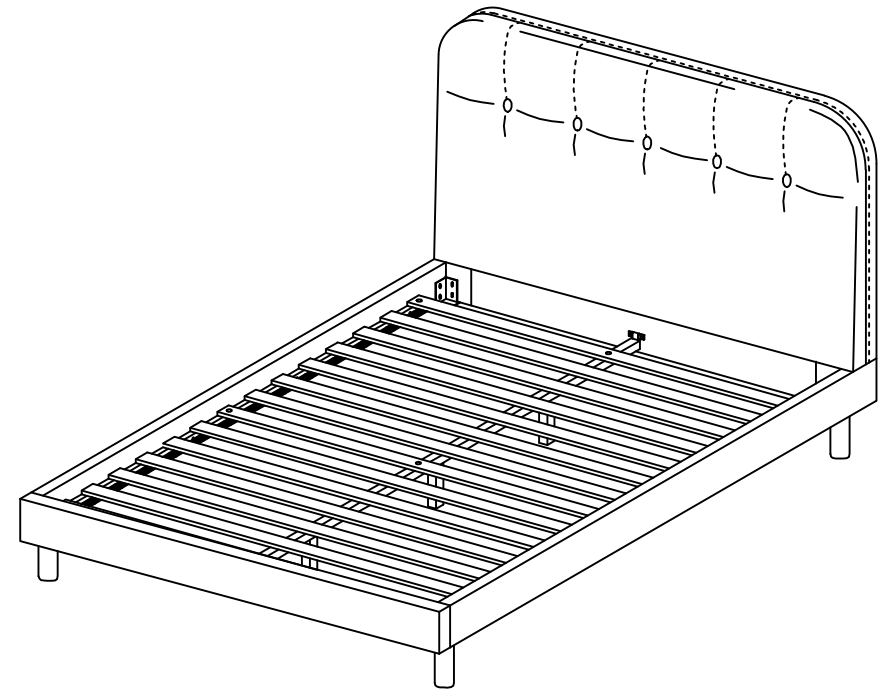

* When moving the bed position, the center support legs must be adjust to be straight to avoid any broken problem.