









Read this instruction carefully. See hardware and furniture part list for guidance. Be sure all parts are complete, before you assemble. Place all wooden furniture parts on a clean and flat soft surface to prevent from being scratched. Follow the figure to start assembling.

CAUTIONS : 1. Do not FULLY - TIGHTEN the nut or nut bolt until all nut or bolt is ready assembled.
 2. Do not OVER - TIGHTEN the nut or bolt to avoid causing damages to the thread.
 3. Keep all hardware parts out of reach of children.

NOTE : THE LIST AND QUANTITY SHOWN ARE FOR 1 UNIT ASSEMBLY.
 Tool needed : Screwdriver (not provider).

PART LIST		
ITEM	DESCRIPTION	QTY
A	HEADBOARD	1 PC
B	FOOTBOARD	1 PC
C	SIDE RAIL	2 PCS
D	CENTER RAIL	1 PC
E	CENTER SUPPORT	2 PCS
F	CENTER SUPPORT LEG	3 PCS
G	BED SLAT	26 PCS
H	BED LEG	4 PCS

HARDWARE LIST		
ITEM	DESCRIPTION	QTY
1	JCBB BOLT M8 x 50mm 	4 PCS
2	JCBB BOLT M8 x 80mm 	16 PCS
3	M8 FLAT WASHER 	20 PCS
4	M8 SPRING WASHER 	20 PCS
5	WOOD SCREW M3.5 x 16mm 	8 PCS
6	WOOD SCREW M4 x 20mm 	2 PCS
7	BED SLAT SIDE FITTER 	26 PCS
8	BED SLAT CENTER FITTER 	13 PCS
9	M5 ALLEN KEY (BALL SHAPE) 	1 PC

STEP 1

STEP A FRONT VIEW

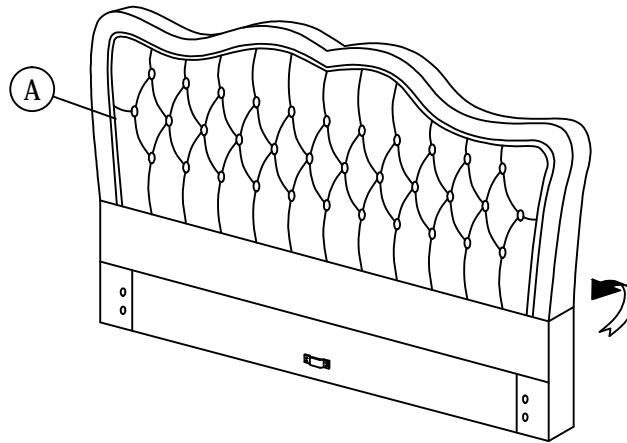

STEP B BACK VIEW

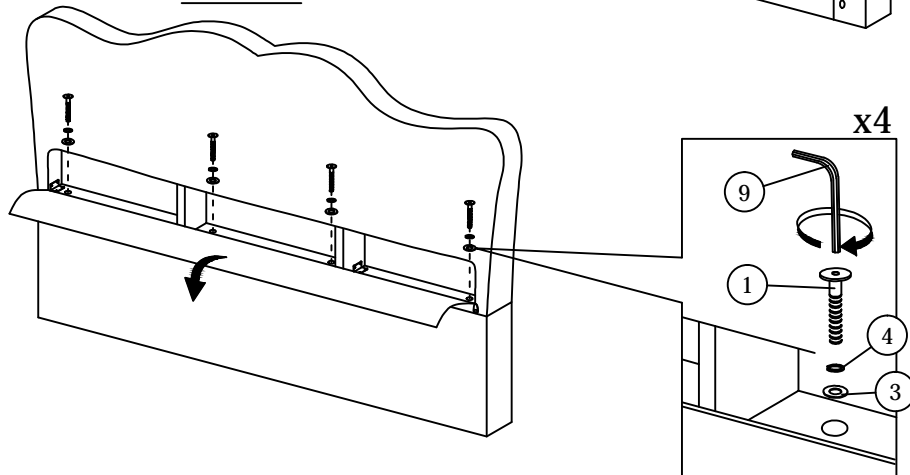

STEP 2

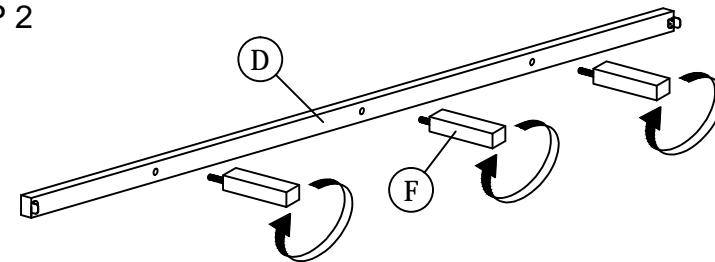

Don't screw tied x4

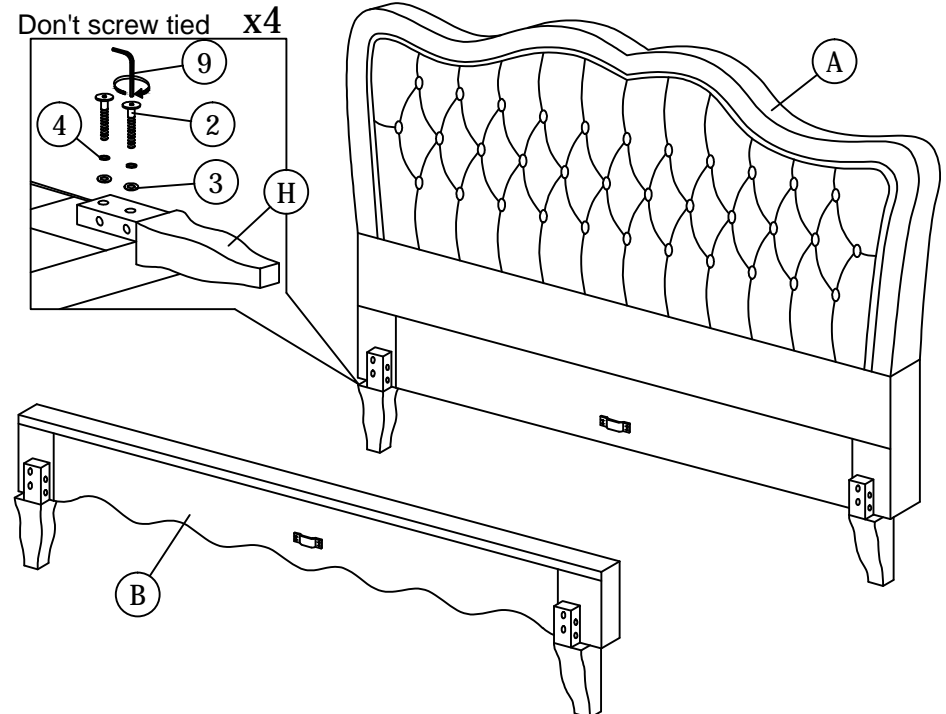

ASSEMBLY INSTRUCTIONS

STEP 3

****Finish step 3,
Please screw tied the step 2 bolt.**

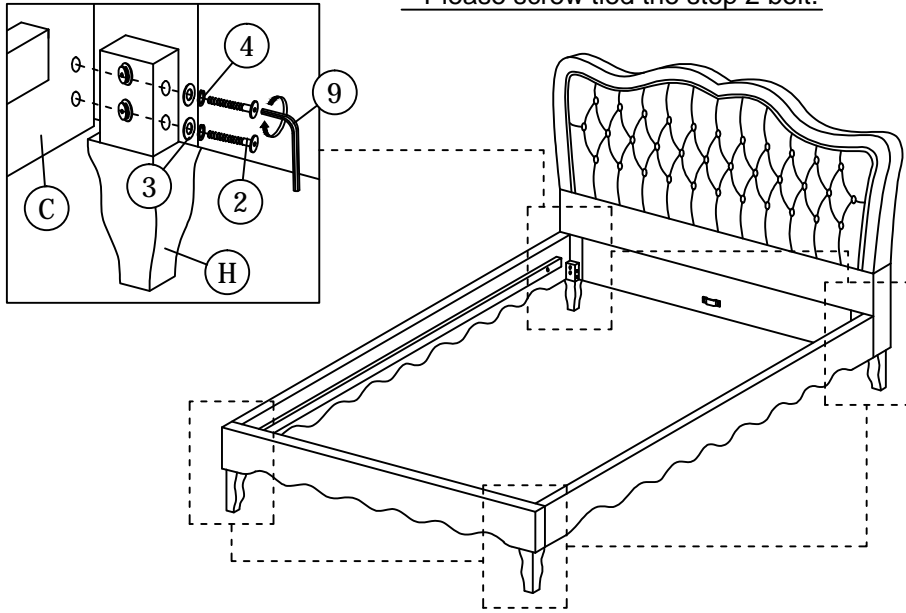

STEP 4

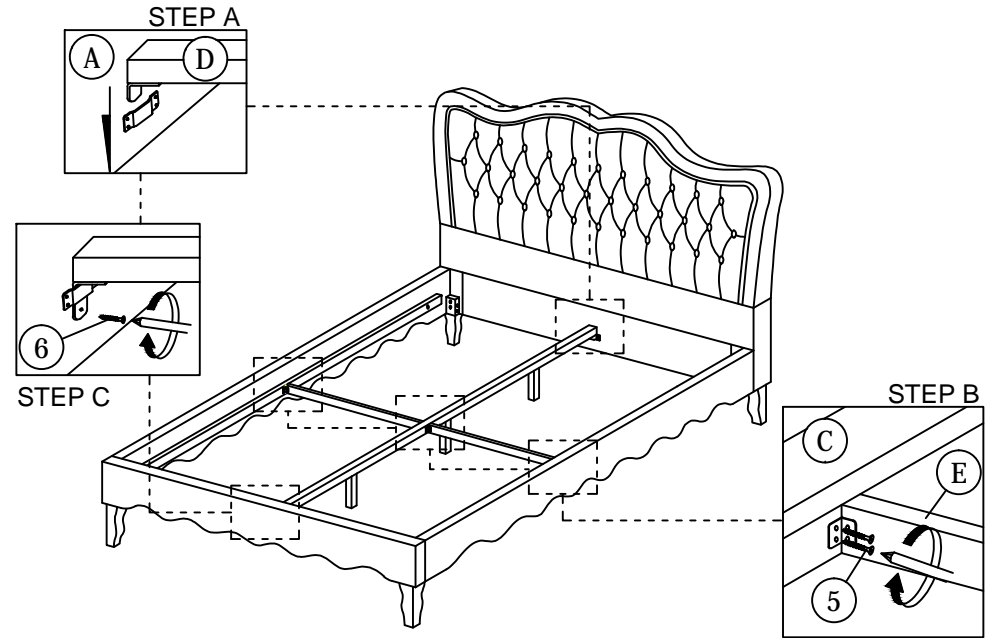

STEP 5

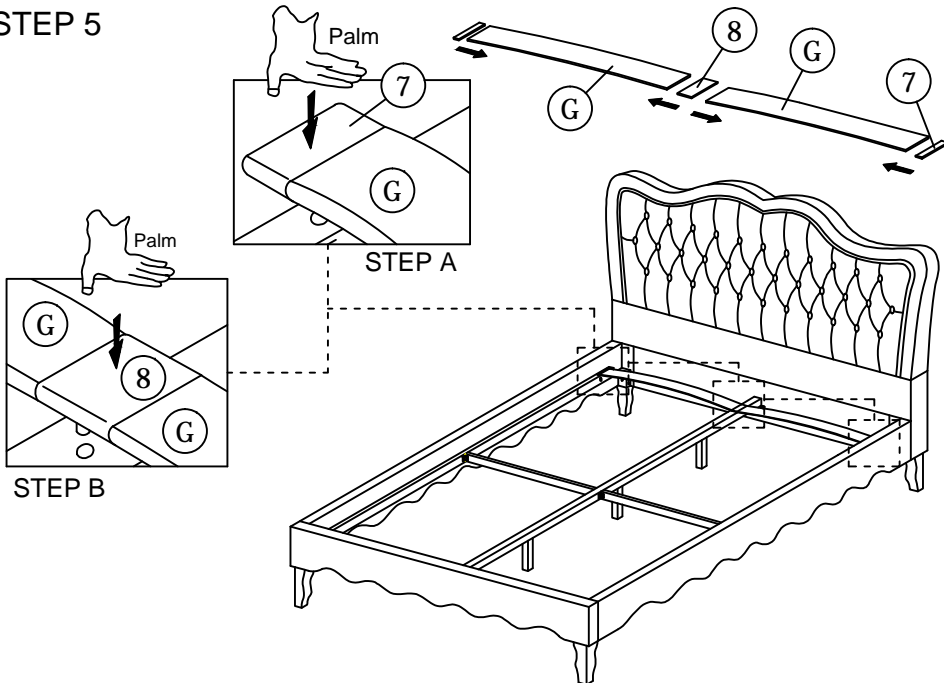

STEP 6

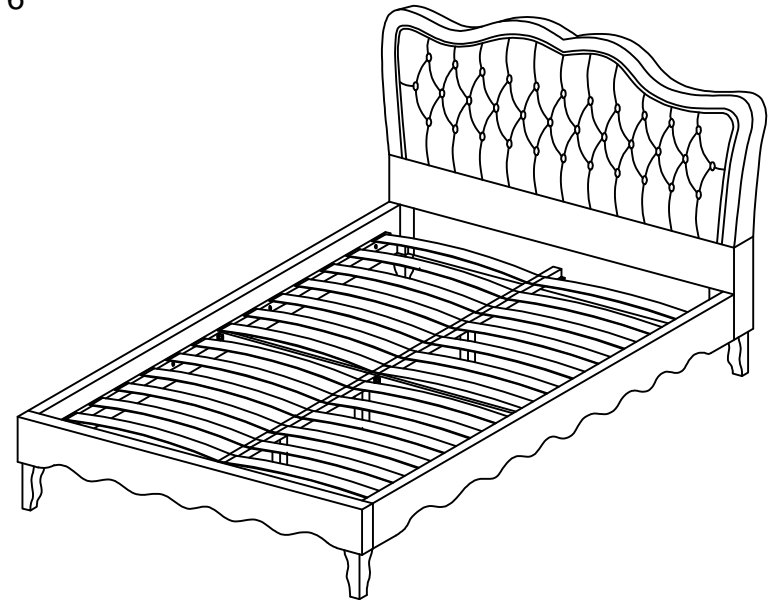

** When moving the bed position, the center support legs must be adjust to be straight to avoid any broken problem.*