

Read this instruction carefully. See hardware and furniture part list for guidance. Be sure all parts are complete, before you assemble. Place all wooden furniture parts on a clean and flat soft surface to prevent from being scratched. Follow the figure to start assembling.

**CAUTIONS :** 1. Do not FULLY - TIGHTEN the nut or nut bolt until all nut or bolt is ready assembly.  
 2. Do not OVER - TIGHTEN the nut or bolt to avoid causing damages to the thread.  
 3. Keep all hardware parts out of reach of children.

**NOTE :** THE LIST AND QUANTITY SHOWN ARE FOR 1 UNIT ASSEMBLY.

Tool needed : Screwdriver (not provider).

PART LIST		
ITEM	DESCRIPTION	QTY
A	HEADBOARD	1 PC
B	FOOTBOARD	1 PC
C	SIDE RAIL	2 PCS
D	CENTER RAIL	1 PC
E	CENTER SUPPORT	2 PCS
F	CENTER SUPPORT LEG	3 PCS
G	BED SLAT	26 PCS
H	BED LEG	4 PCS

HARDWARE LIST		
ITEM	DESCRIPTION	QTY
1	JCBC BOLT M6 x 20mm	8 PCS
2	M6 FLAT WASHER	8 PCS
3	M6 SPRING WASHER	8 PCS
4	WOOD SCREW M3.5 x 16mm	8 PCS
5	WOOD SCREW M4 x 25mm	8 PCS
6	BED SLAT SIDE FITTER	26 PCS
7	BED SLAT CENTER FITTER	13 PCS
8	WOOD SCREW M4 x 20mm	2 PCS
9	M4 ALLEN KEY (BALL SHAPE)	1 PC
10	M5 ALLEN KEY (BALL SHAPE)	1 PC

## STEP 1

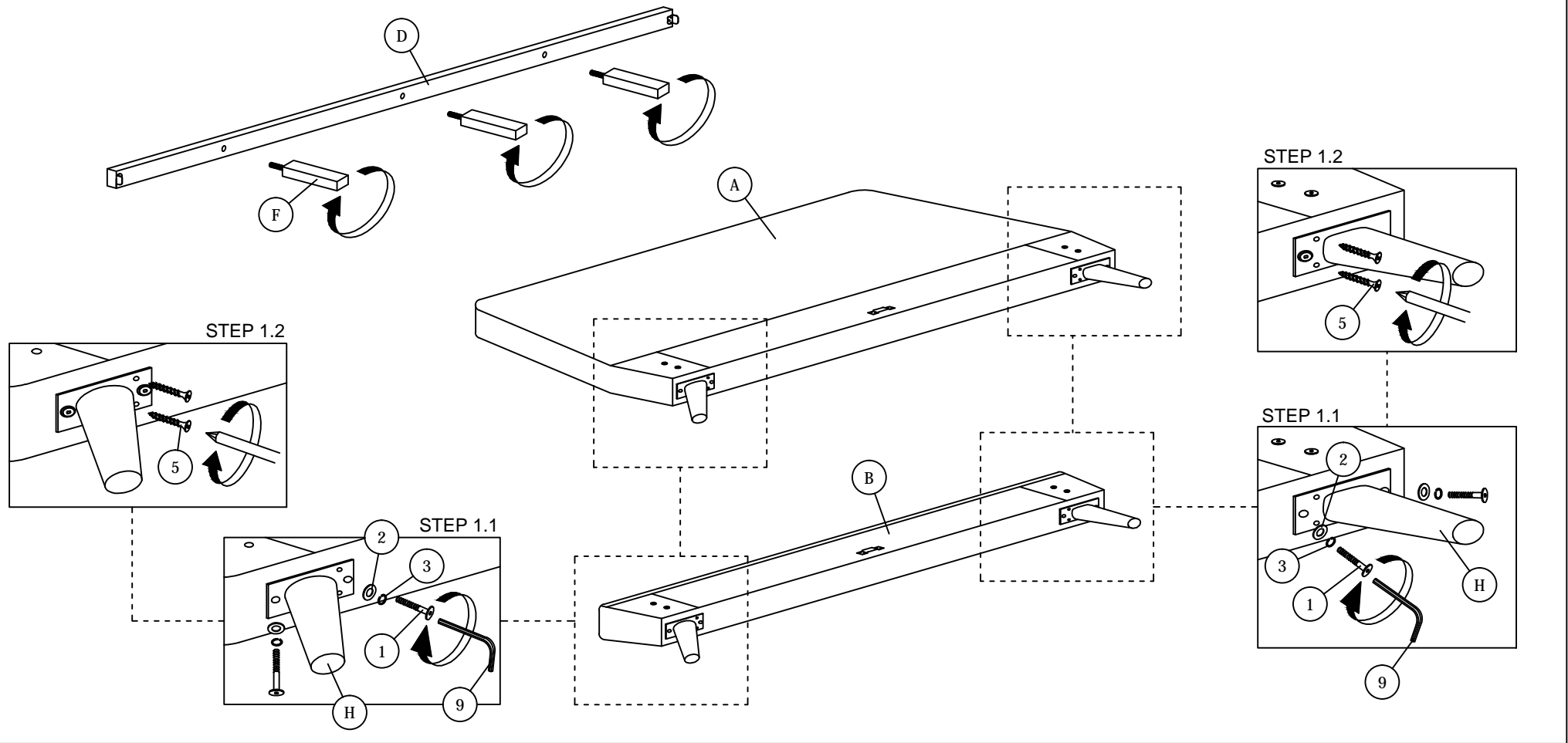

# ASSEMBLY INSTRUCTIONS

## STEP 2

Loosen the pre-inserted bolt on the headboard using Allen key ball shape (10).

### STEP 2.1

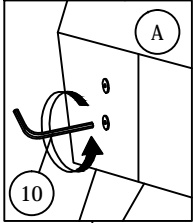

### STEP 2.2

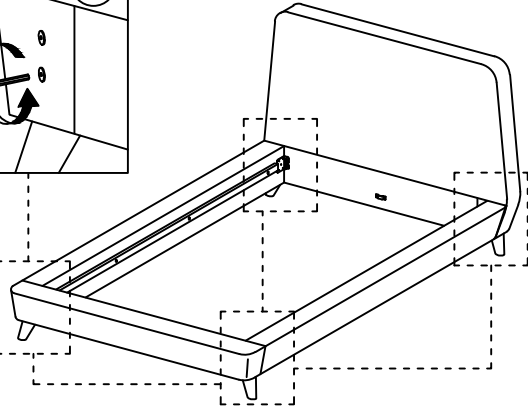
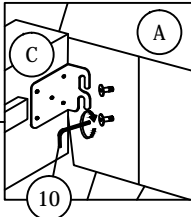

## STEP 3

### STEP 3.1

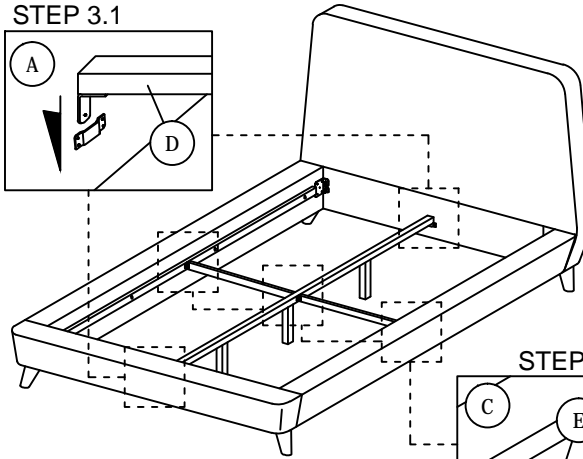
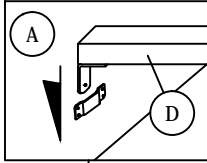

### STEP 3.2

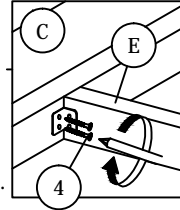

Note: Assemble (E) vertically as picture shown.

## STEP 4

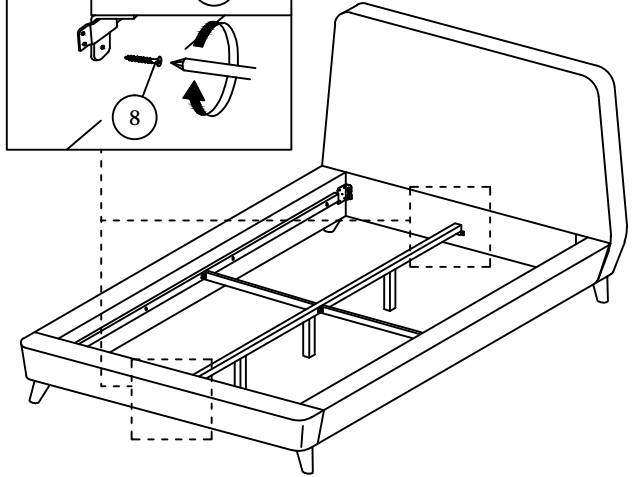
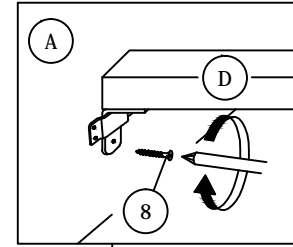

## STEP 5

### STEP 5.1

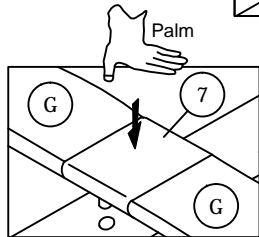
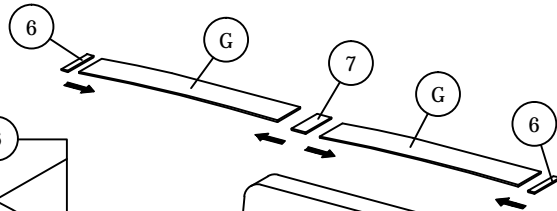
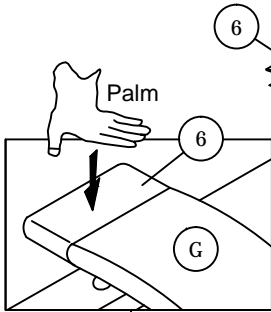

### STEP 5.2

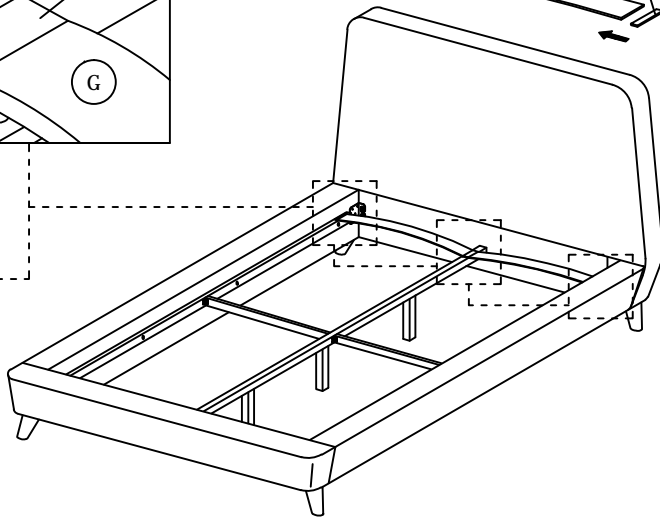

## STEP 6

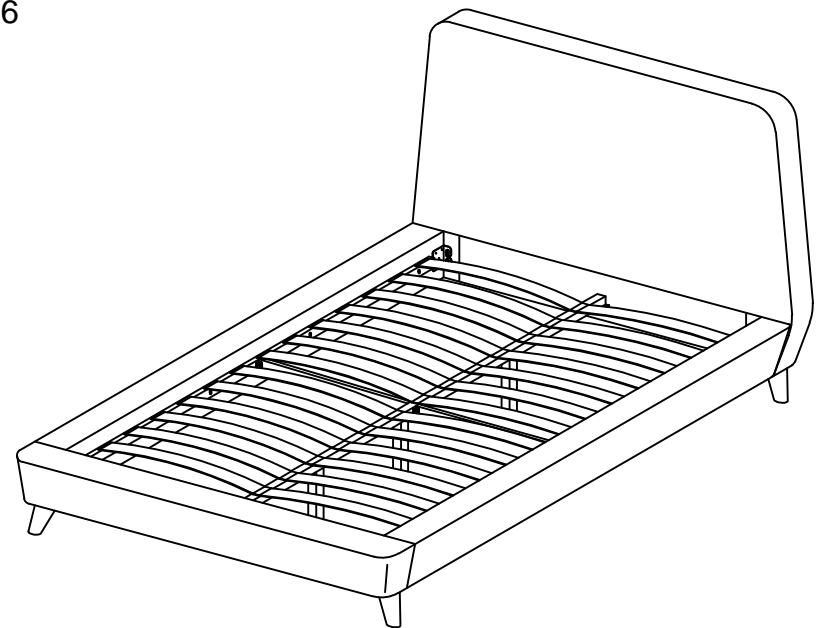

\* When moving the bed position, the center support legs must be adjust to be straight to avoid any broken problem.