

Read this instruction carefully. See hardware and furniture part list for guidance. Be sure all parts are complete, before you assemble. Place all wooden furniture parts on a clean and flat soft surface to prevent from being scratched. Follow the figure to start assembling.

- CAUTIONS :**
1. Do not FULLY - TIGHTEN the nut or nut bolt until all nut or bolt is ready assembled.
 2. Do not OVER - TIGHTEN the nut or bolt to avoid causing damages to the thread.
 3. Keep all hardware parts out of reach of children.

NOTE : THE LIST AND QUANTITY SHOWN ARE FOR 1 UNIT ASSEMBLY.
Tool needed : Screwdriver (not provider).

PART LIST		
ITEM	DESCRIPTION	QTY
A	HEADBOARD	1 PC
B	FOOTBOARD	1 PC
C	SIDE RAIL (L&R)	2 PCS
D	CENTER RAIL	2 PCS
E	CENTER SUPPORT LEG	6 PCS
F	CENTER SUPPORT	3 PCS
G	LEG (L&R)	2 PCS
H	BED SLAT	39 PCS

HARDWARE LIST		
ITEM	DESCRIPTION	QTY
1	JCBC BOLT M6 x 20mm	8 PCS
2	JCBB BOLT M8 x 16mm	4 PCS
3	JCBB BOLT M8 x 30mm	6 PCS
4	M6 SPRING WASHER	8 PCS
5	M6 FLAT WASHER	8 PCS
6	M8 SPRING WASHER	2 PCS
7	M8 FLAT WASHER	2 PCS
8	M4 ALLEN KEY (BALL SHAPE)	1 PC
9	M5 ALLEN KEY (BALL SHAPE)	1 PC
10	WOOD SCREW M3.5 x 16mm	12 PCS
11	BED SLAT CENTER FITTER	26 PCS
12	BED SLAT SIDE FITTER	26 PCS

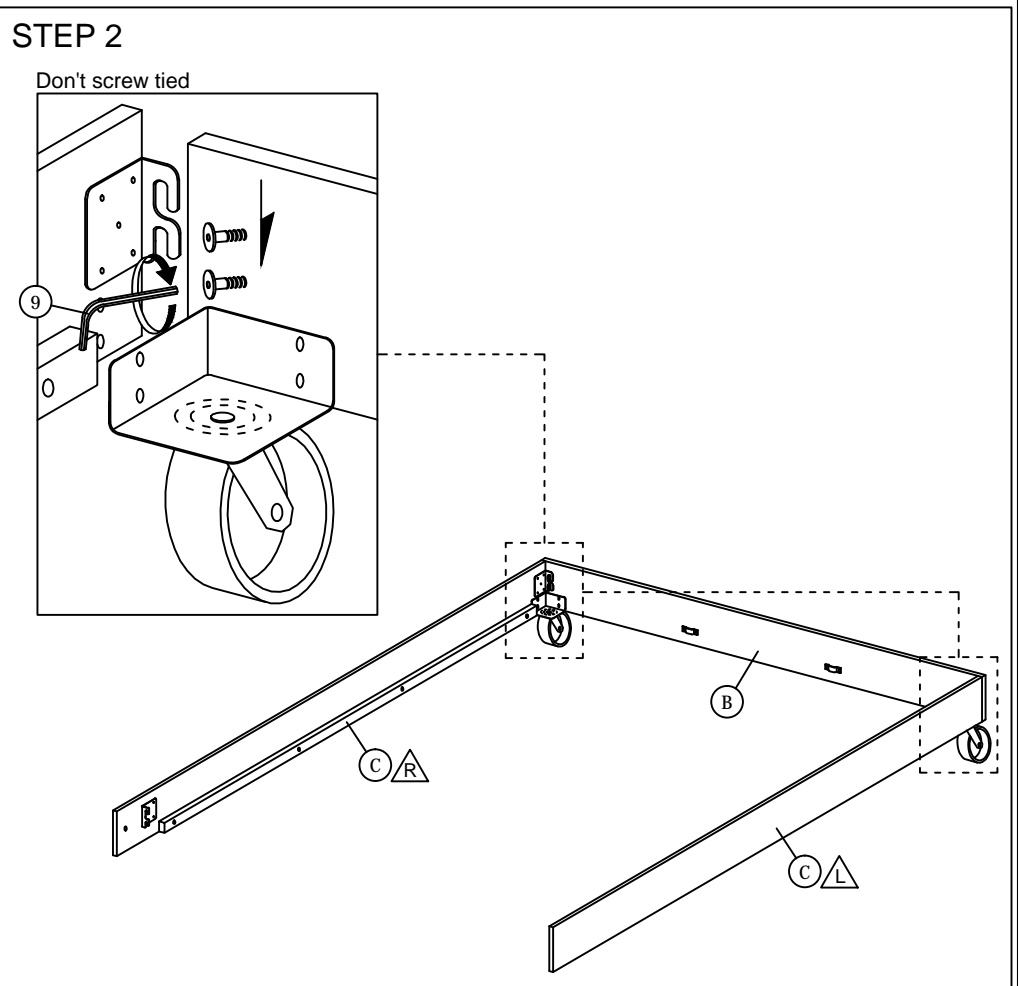
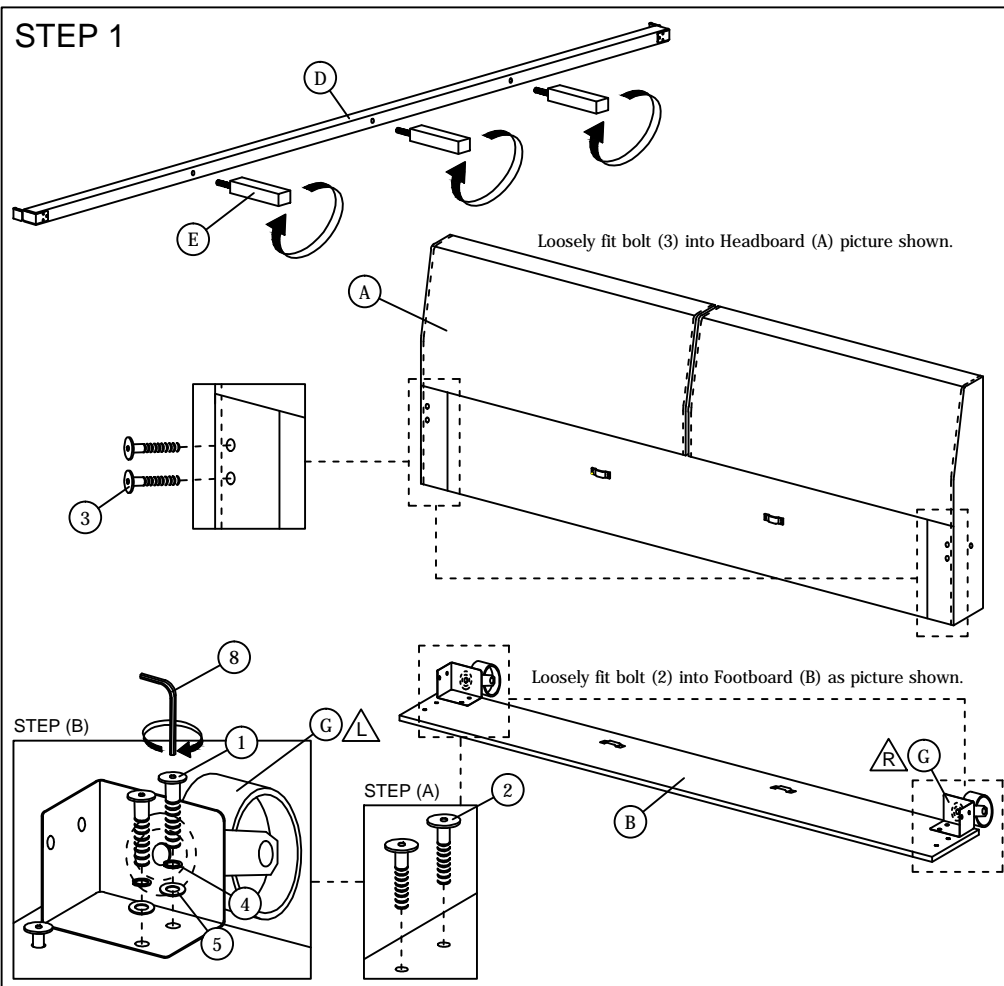

ASSEMBLY INSTRUCTIONS

STEP 3

STEP (B)

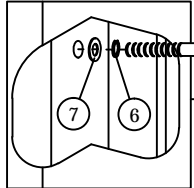

Back view(Headboard)

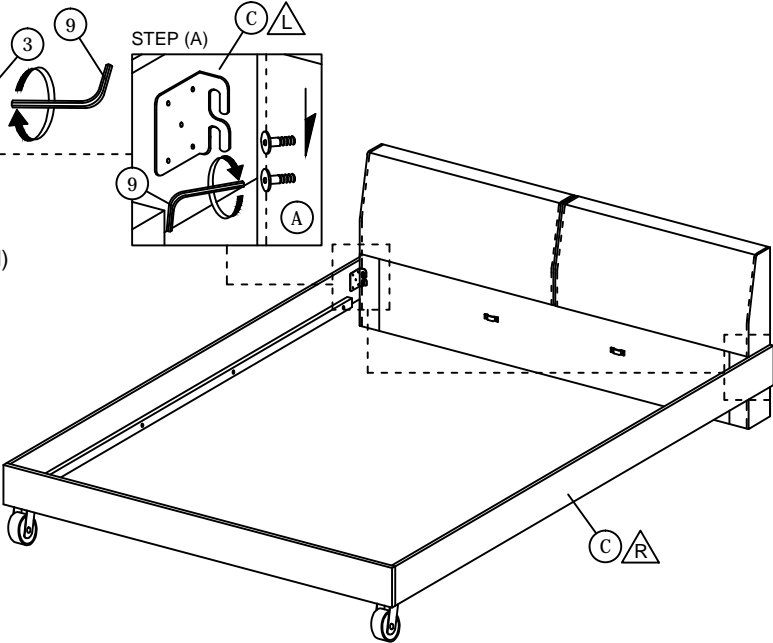

**Finish step 3.
Please screw tied the step 2 bolt.

STEP 4

STEP (A)

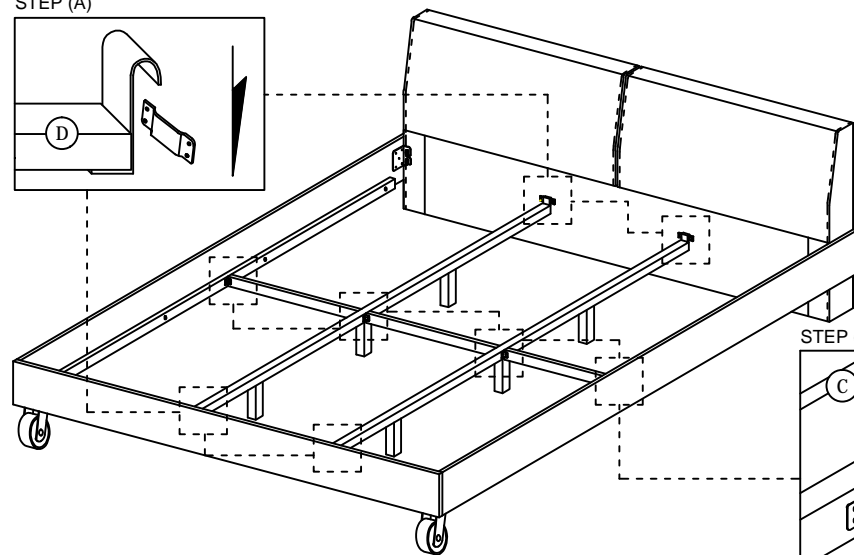
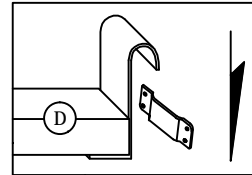

Note: Assemble (F) vertically as picture shown

STEP 5

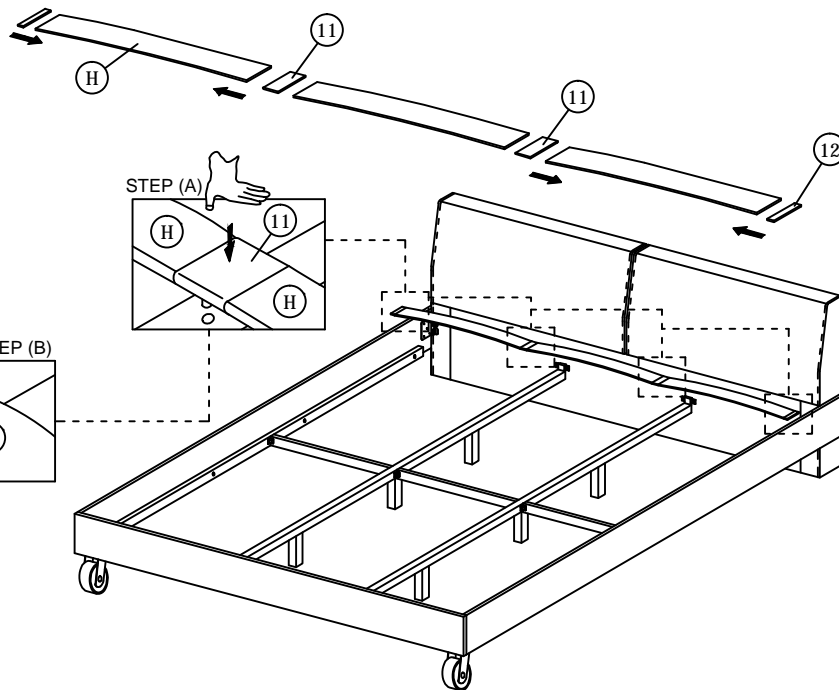

STEP 6

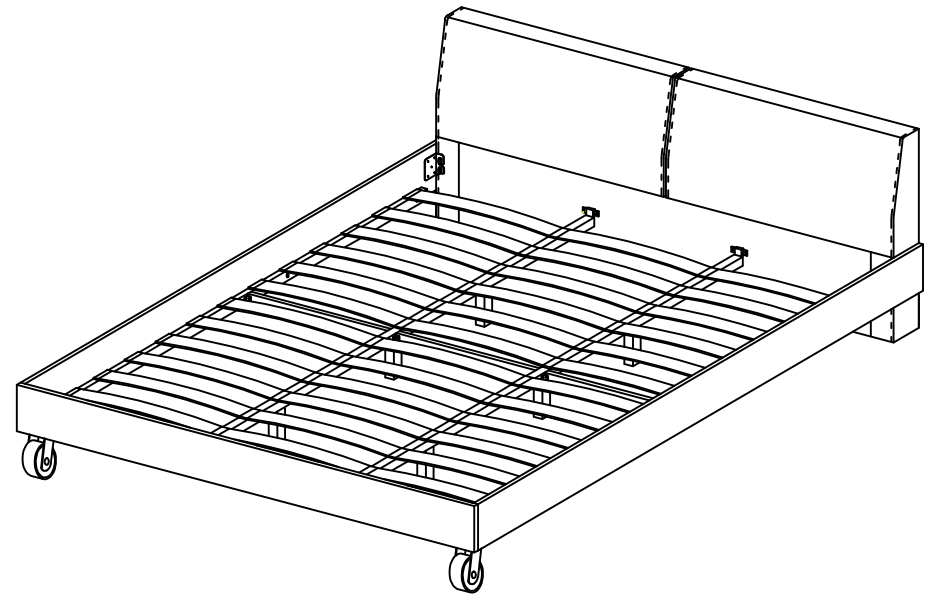

* When moving the bed position, the center support legs must be adjust to be straight to avoid any broken problem.