

Read this instruction carefully. See hardware and furniture part list for guidance. Be sure all parts are complete, before you assemble. Place all wooden furniture parts on a clean and flat soft surface to prevent from being scratched. Follow the figure to start assembling.

CAUTIONS : 1. Do not FULLY - TIGHTEN the nut or nut bolt until all nut or bolt is ready assembled.
2. Do not OVER - TIGHTEN the nut or bolt to avoid causing damages to the thread.
3. Keep all hardware parts out of reach of children.

| PART LIST | | |
|-----------|---------------|-------|
| ITEM | DESCRIPTION | QTY |
| A | CHAIR | 1 PC |
| B | CHAIR LEG | 4 PCS |
| C | METAL BRACKET | 2 PCS |

| HARDWARE LIST | | |
|---------------|---|--------|
| ITEM | DESCRIPTION | QTY |
| 1 | JCBC BOLT M6 x 20mm  | 16 PCS |
| 2 | M6 FLAT WASHER  | 16 PCS |
| 3 | M6 SPRING WASHER  | 16 PCS |
| 4 | M4 ALLEN KEY (BALL SHAPE)  | 1 PC |

NOTE : THE LIST AND QUANTITY SHOWN ARE FOR 1 UNIT ASSEMBLY.

STEP 1

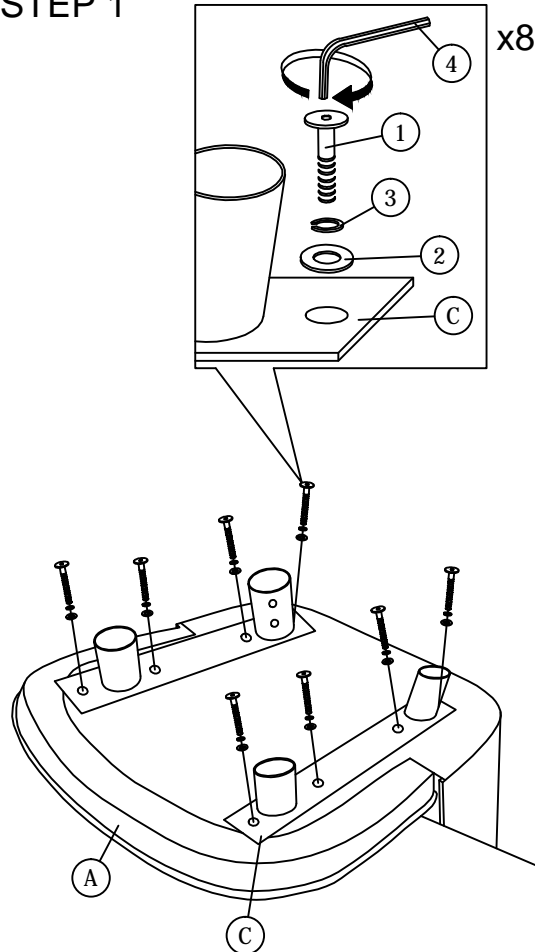

STEP 2

STEP 2.1

Attach the chair leg [B] to the chair [A], using the JCBC Bolt M6 x 20mm (1), M6 Flat Washer (2) and M6 Spring Washer (3) using M4 Allen Key (4).

NOTE : Don't Screw tied.

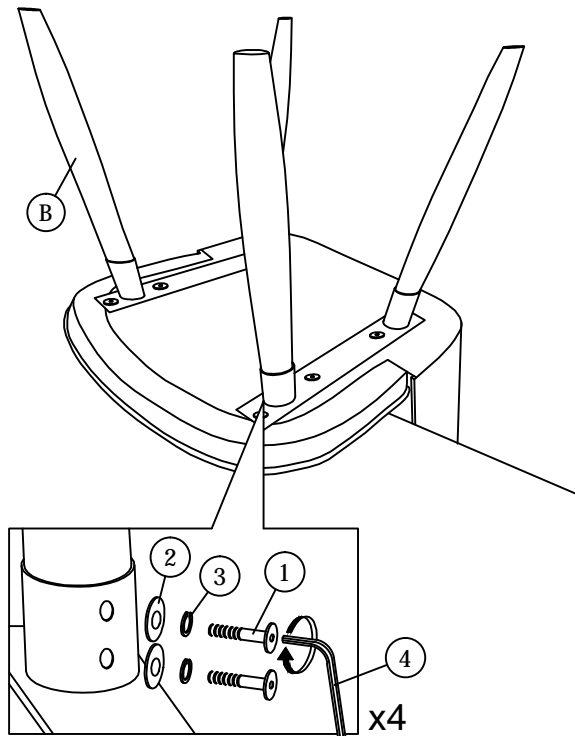

STEP 2.2

Place the chair on the flat place and adjust the alignment and balance of the legs then, tighten the screw.

