







Read this instruction carefully. See hardware and furniture part list for guidance. Be sure all parts are complete, before you assemble. Place all wooden furniture parts on a clean and flat soft surface to prevent from being scratched. Follow the figure to start assembling.

**CAUTIONS :** 1. Do not FULLY - TIGHTEN the nut or nut bolt until all nut or bolt is ready assembled.  
 2. Do not OVER - TIGHTEN the nut or bolt to avoid causing damages to the thread.  
 3. Keep all hardware parts out of reach of children.

**NOTE :** THE LIST AND QUANTITY SHOWN ARE FOR 1 UNIT ASSEMBLY.

Tool needed : Screwdriver (not provided).

PART LIST		
ITEM	DESCRIPTION	QTY
A	CHAIR	1 PC
B	FRONT LEG	2 PCS
C	BACK LEG	2 PCS
D	RAIL	2 PCS
E	SUPPORT WOOD	1 PC

HARDWARE LIST		
ITEM	DESCRIPTION	QTY
1	JCBC BOLT M6 x 45mm 	8 PCS
2	M6 FLAT WASHER 	8 PCS
3	M6 SPRING WASHER 	8 PCS
4	WOOD SCREW M4 x 32mm 	2 PCS
5	WOOD SCREW M4 x 45mm 	4 PCS
6	M4 ALLEN KEY (BALL SHAPE) 	1 PC

## STEP 1

### STEP 1.1

Take out the leg from the bottom of seat.

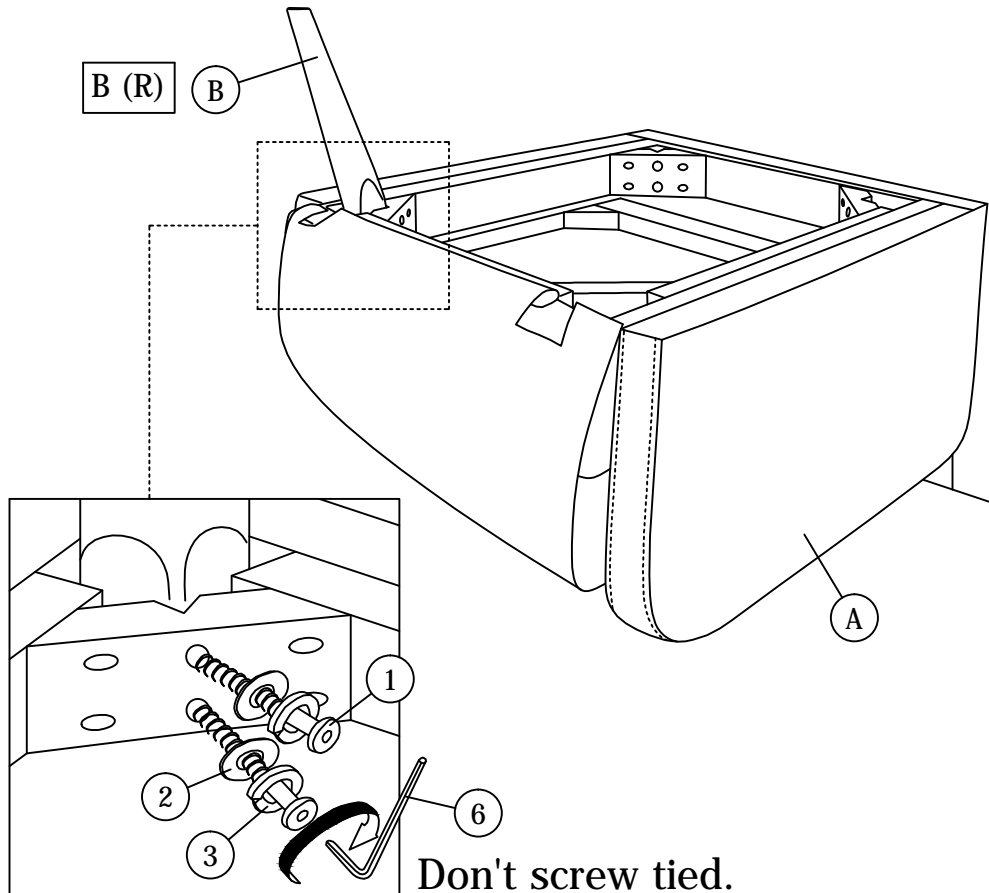

## STEP 2

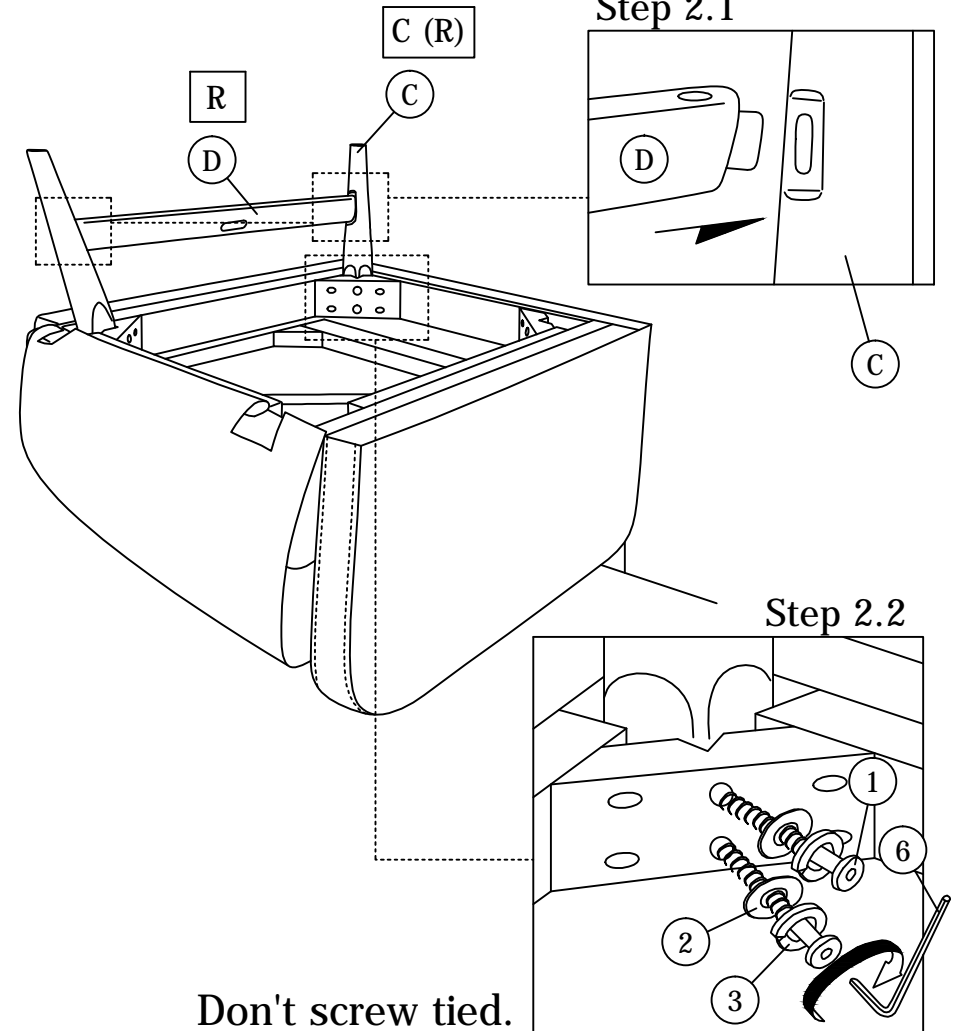

# ASSEMBLY INSTRUCTIONS

## STEP 3

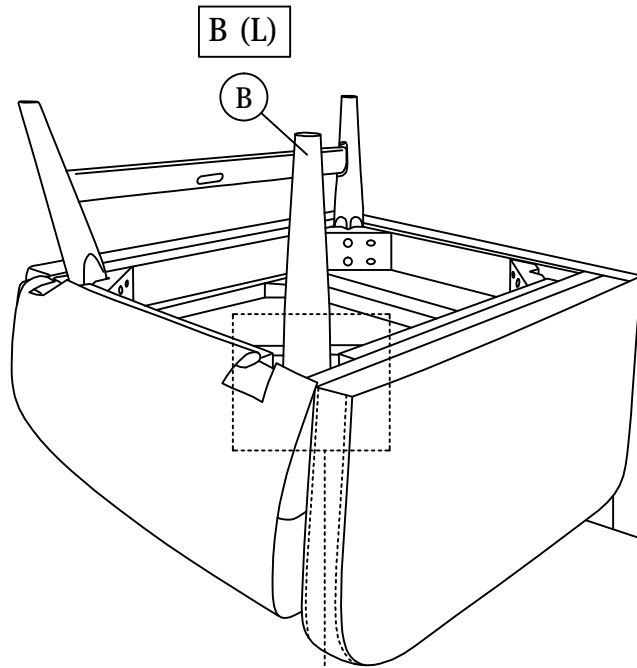

Don't screw tied.

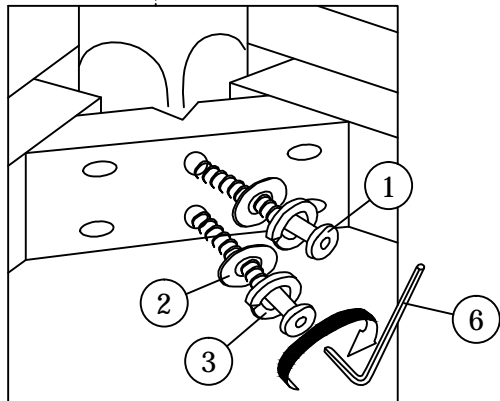

## STEP 4

### Step 4.1

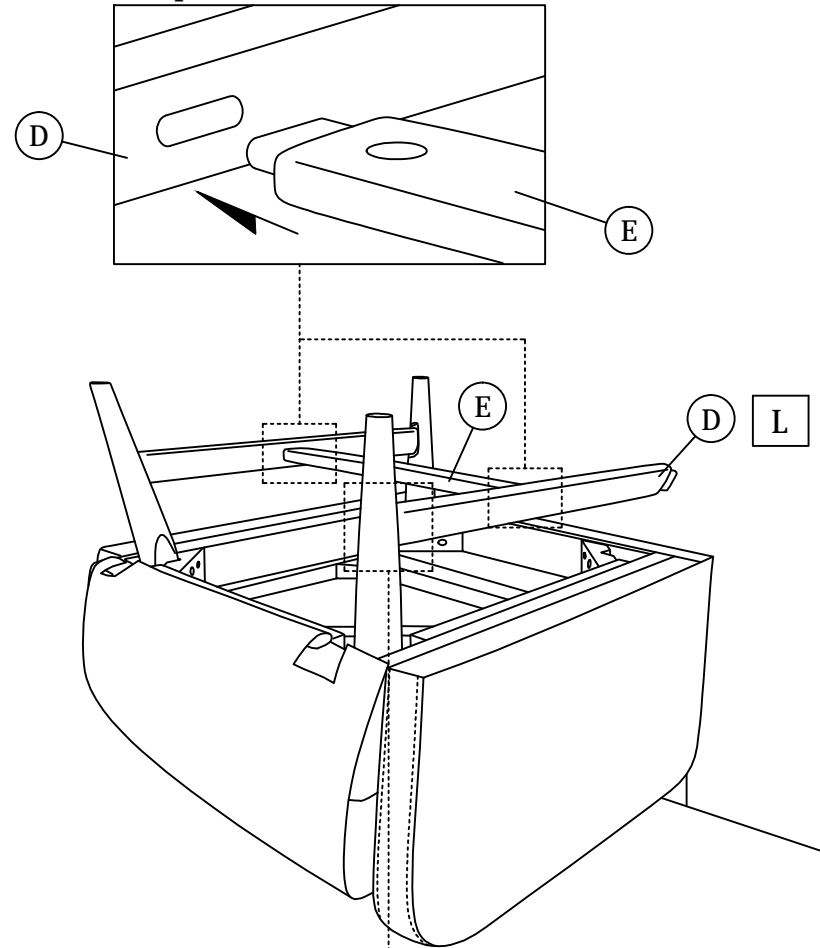

### Step 4.2

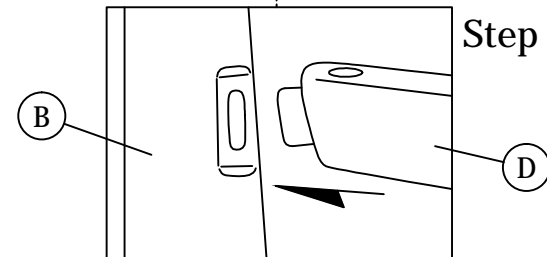

# ASSEMBLY INSTRUCTIONS

## STEP 5

### Step 5.1

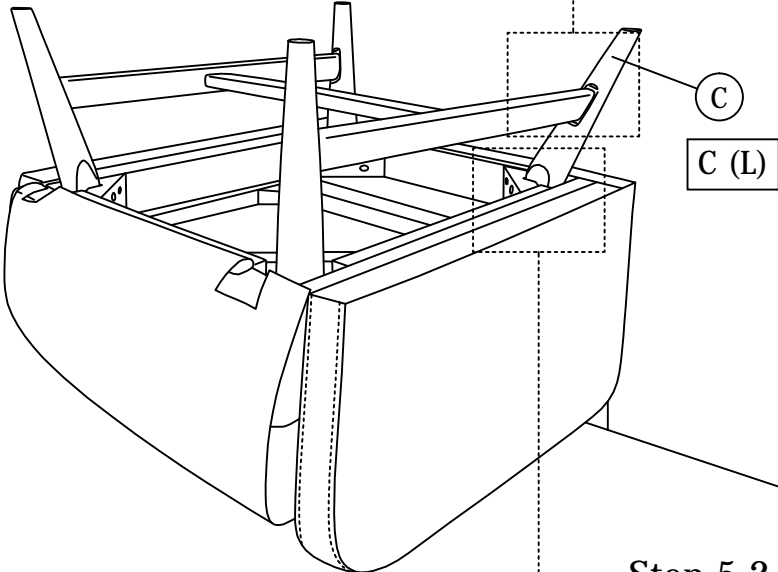
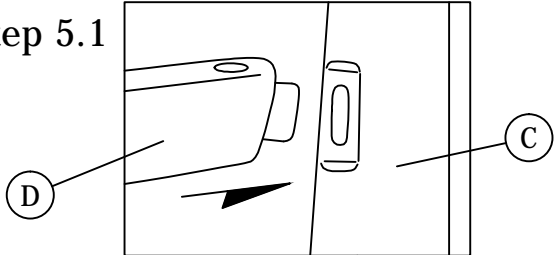

### Step 5.2

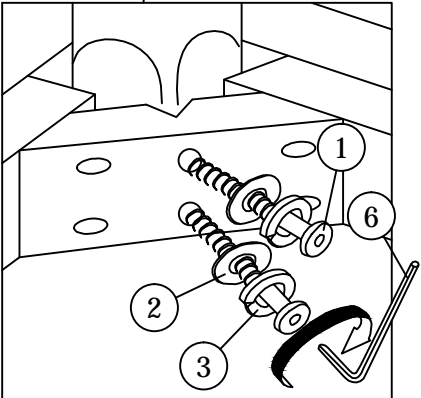

Don't screw tied.

## STEP 6

x 4

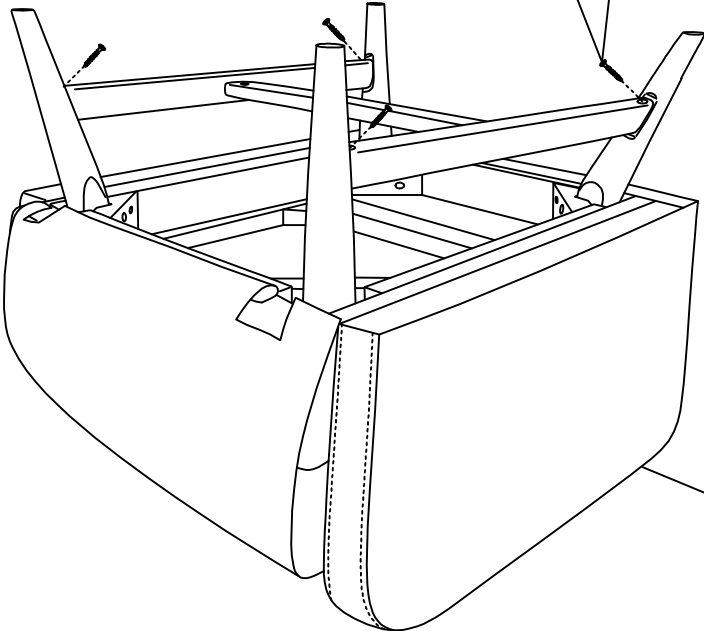
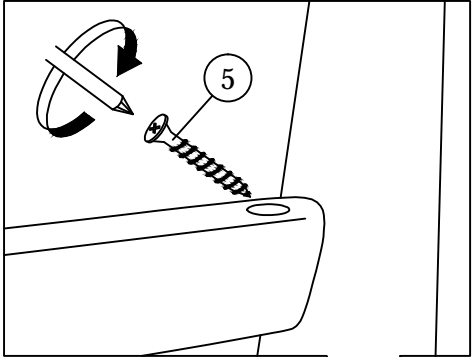

# ASSEMBLY INSTRUCTIONS

## STEP 7

x 2

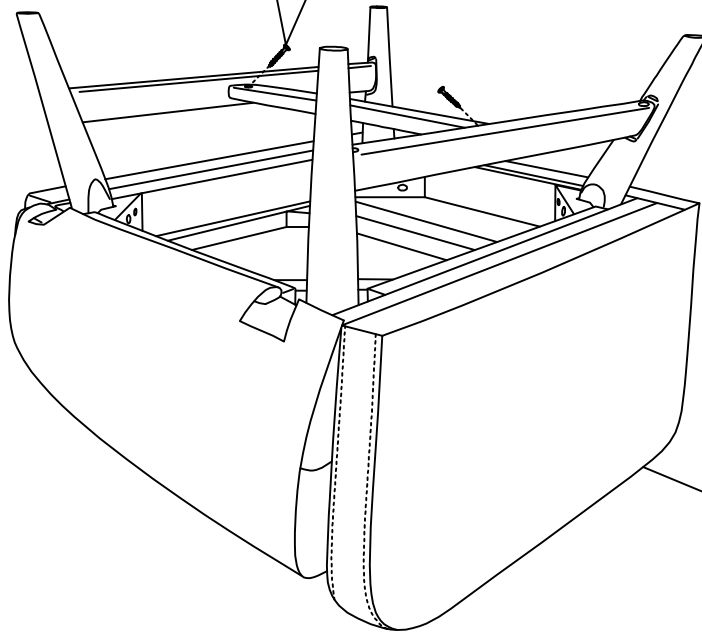
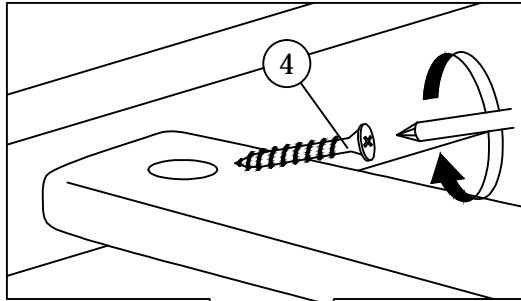

## STEP 8

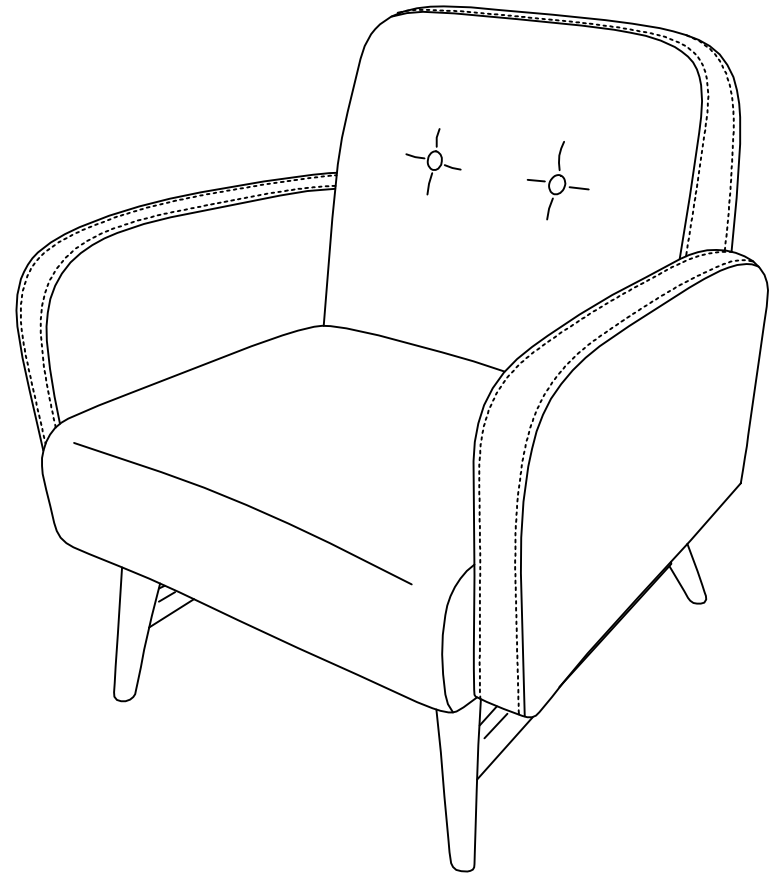

**\*\*Finish step 7,  
Please screw tied the step 1,2,3,5 bolt.**