

Read this instruction carefully. See hardware and furniture part list for guidance. Be sure all parts are complete, before you assemble. Place all wooden furniture parts on a clean and flat soft surface to prevent from being scratched. Follow the figure to start assembling.

CAUTIONS : 1. Do not FULLY - TIGHTEN the nut or nut bolt until all nut or bolt is ready assembled.
 2. Do not OVER - TIGHTEN the nut or bolt to avoid causing damages to the thread.
 3. Keep all hardware parts out of reach of children.

NOTE : THE LIST AND QUANTITY SHOWN ARE FOR 1 UNIT ASSEMBLY.

Tool needed : Screwdriver & Hammer (not provided).

PART LIST		
ITEM	DESCRIPTION	QTY
A	CHAIR FRAME	1pc
B	CHAIR LEG (L)	1pc
C	CHAIR LEG (R)	1pc
D	FRONT STRETCHER	1pc
E	BACK STRETCHER	1pc

HARDWARE LIST		
ITEM	DESCRIPTION	QTY
1	JCBC Bolt M6 x 45mm	8pcs
2	M6 Spring Washer	8pcs
3	WOOD SCREW M4 x 32mm	4pcs
4	Wood Dowel M8 x 30mm	4pcs
5	M4 Allen Key (Ball Shape)	1pc

STEP 1

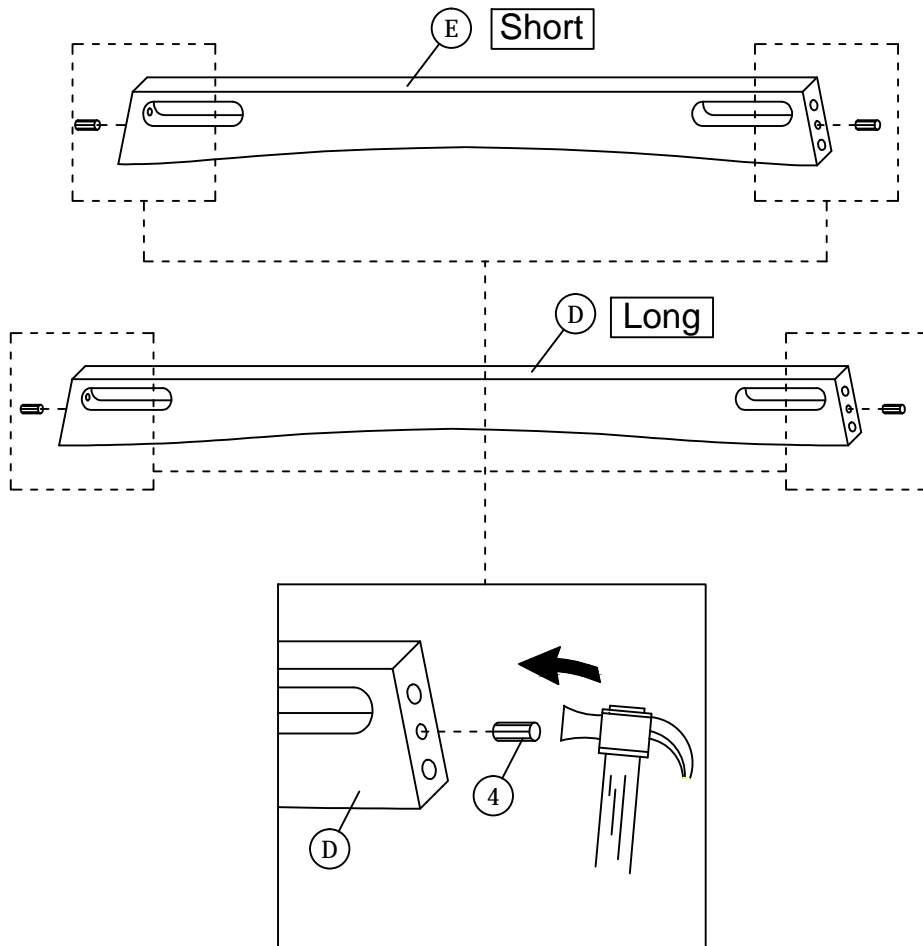

STEP 2

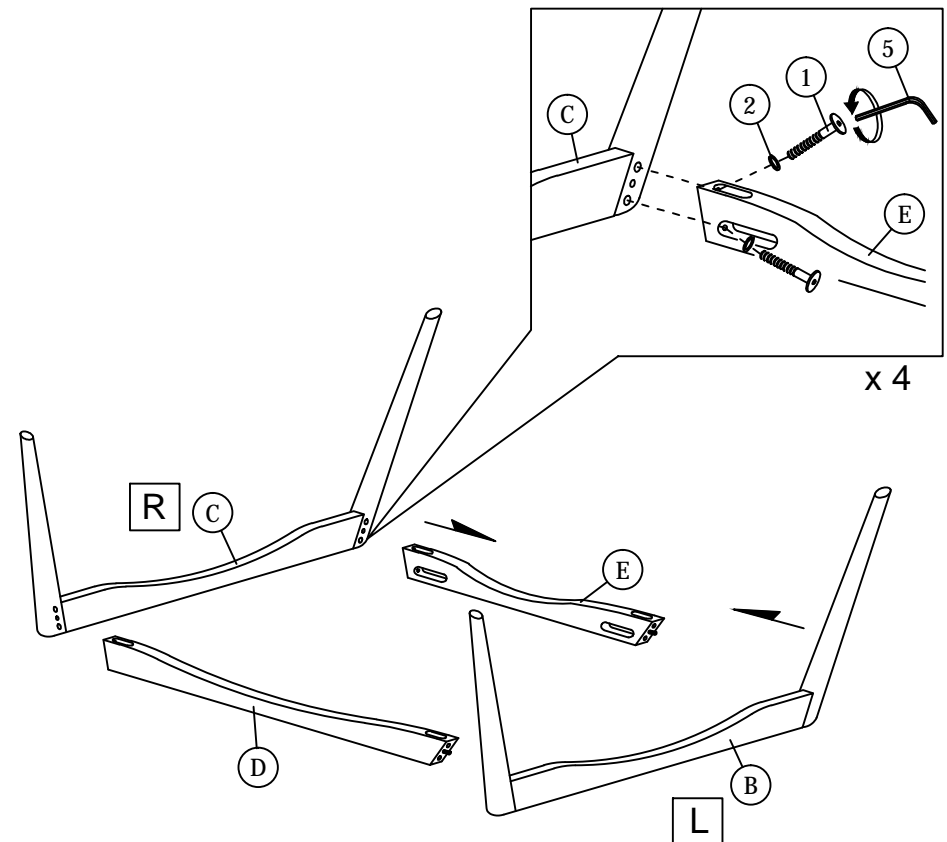

ASSEMBLY INSTRUCTIONS

STEP 3

Note : Follow the line drawing to assemble the chair leg.

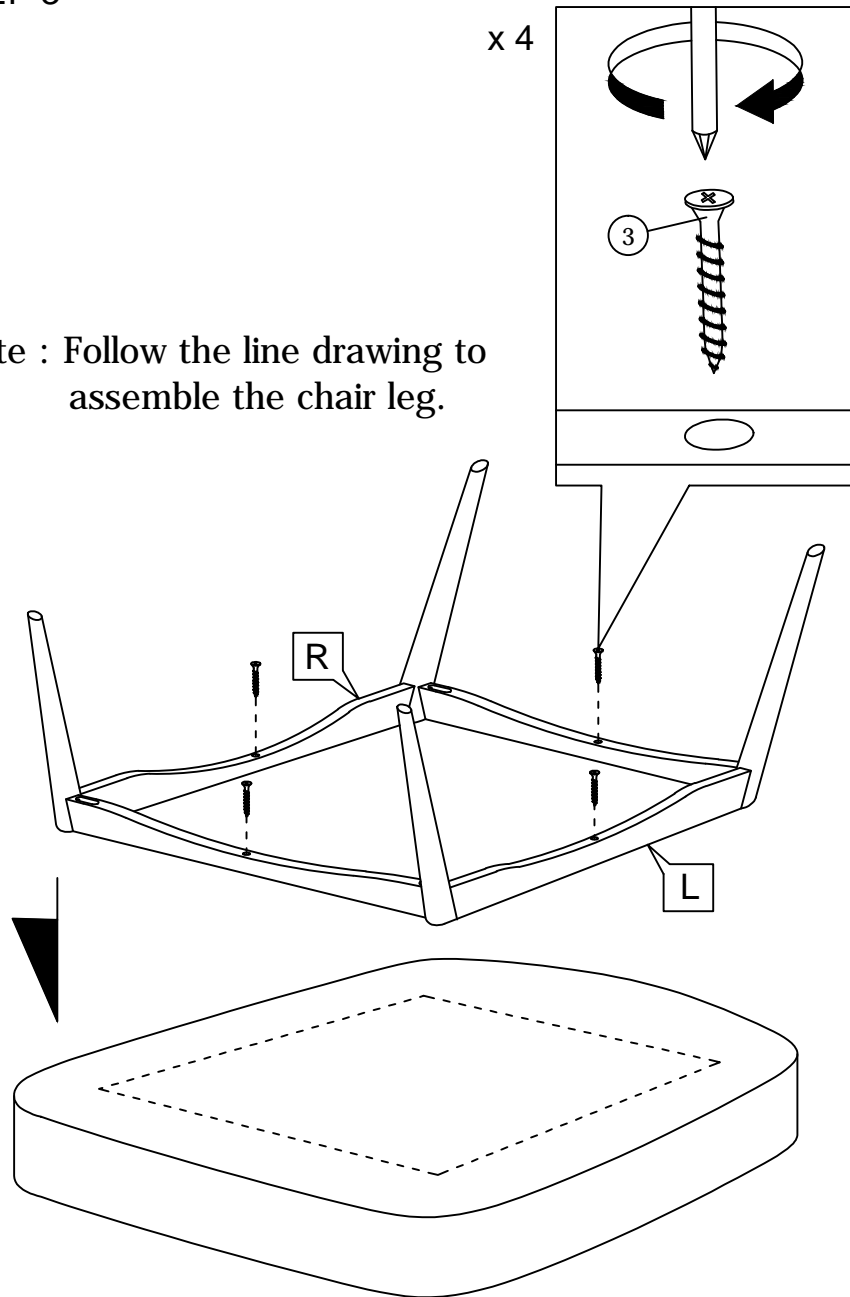

STEP 4

