

MODEL : BBT5267 ARM CHAIR

ASSEMBLY INSTRUCTIONS







Read this instruction carefully. See hardware and furniture part list for guidance. Be sure all parts are complete, before you assemble. Place all wooden furniture parts on a clean and flat soft surface to prevent from being scratched. Follow the figure to start assembling.

- CAUTIONS :**
1. Do not FULLY - TIGHTEN the nut or nut bolt until all nut or bolt is ready assembled.
 2. Do not OVER - TIGHTEN the nut or bolt to avoid causing damages to the thread.
 3. Keep all hardware parts out of reach of children.

NOTE : THE LIST AND QUANTITY SHOWN ARE FOR 1 UNIT ASSEMBLY.

Tool needed : Screwdriver (not provider).

PART LIST		
ITEM	DESCRIPTION	QTY
A	CHAIR BACK	1 PC
B	CUSHION SEAT FRAME	1 PC
C	ARM (L)	1 PC
D	ARM (R)	1 PC

HARDWARE LIST		
ITEM	DESCRIPTION	QTY
1	JCBC Bolt M6 x 40mm 	6pcs
2	JCBC Bolt M6 x 70mm 	2pcs
3	JCBC Bolt M6 x 80mm 	2pcs
4	Wood SCREW M4 x 38mm 	2pcs
5	M6 SPRING WASHER 	10pcs
6	M6 FLAT WASHER 	10pcs
7	M4 ALLEN KEY (BALL SHAPE) 	1pc

STEP 1

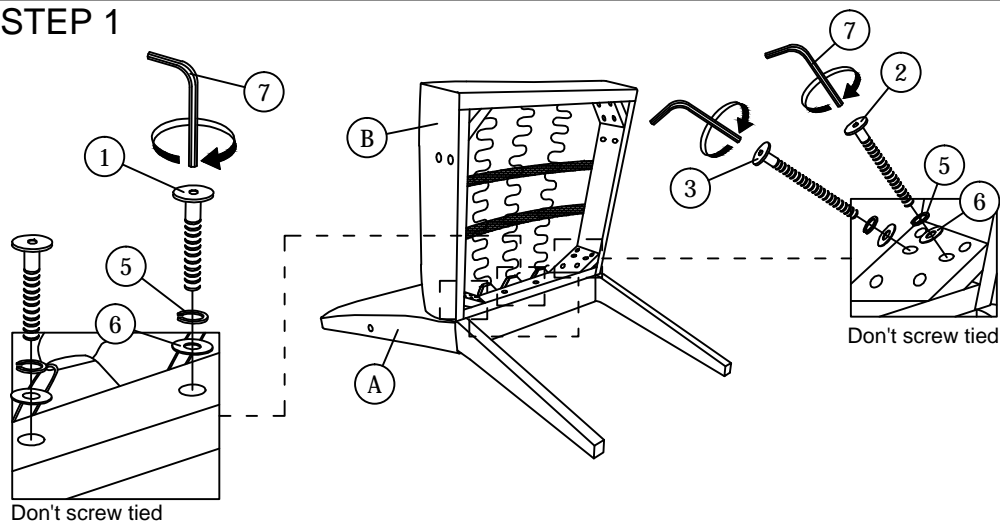

STEP 2

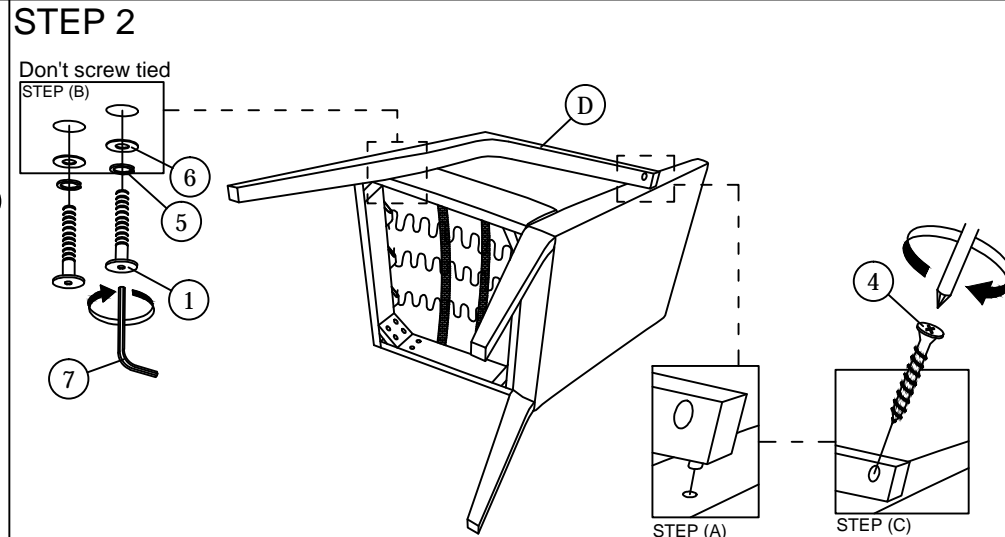

STEP 3

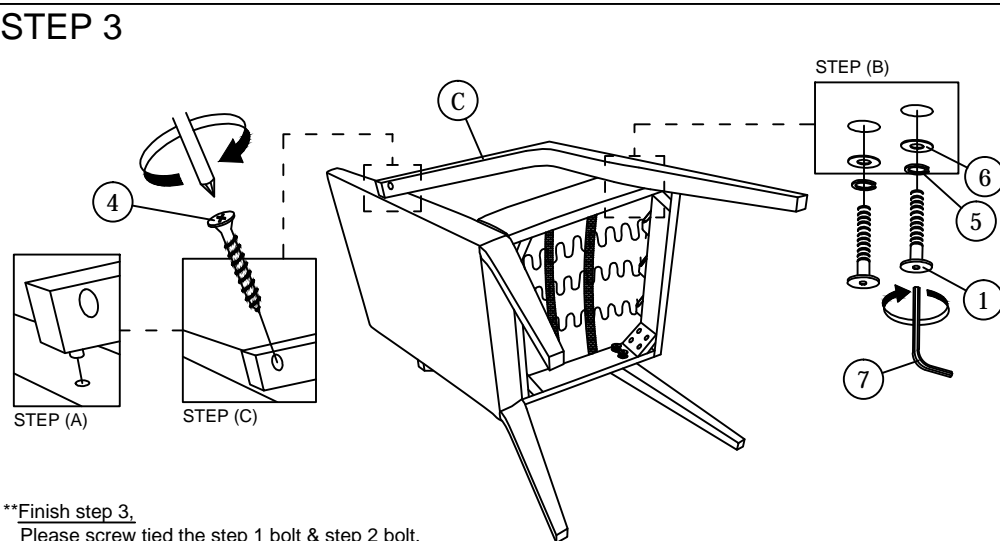

STEP 4

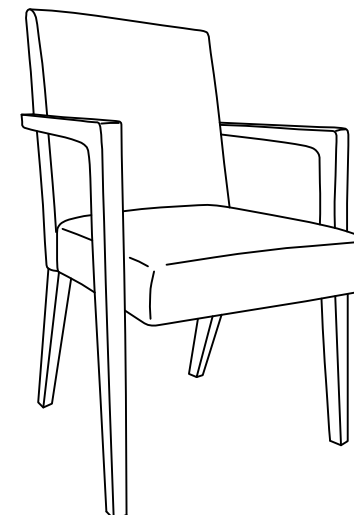

**Finish step 3.
Please screw tied the step 1 bolt & step 2 bolt.