







Read this instruction carefully. See hardware and furniture part list for guidance. Be sure all parts are complete, before you assemble. Place all wooden furniture parts on a clean and flat soft surface to prevent from being scratched. Follow the figure to start assembling.

CAUTIONS : 1. Do not FULLY - TIGHTEN the nut or nut bolt until all nut or bolt is ready assembled.
 2. Do not OVER - TIGHTEN the nut or bolt to avoid causing damages to the thread.
 3. Keep all hardware parts out of reach of children.

NOTE : THE LIST AND QUANTITY SHOWN ARE FOR 1 UNIT ASSEMBLY.
 Tool needed : Hammer (not provided).

PART LIST		
ITEM	DESCRIPTION	QTY
A	BACK	1 PC
B	SEAT	1 PC
C	ARM	2 PCS
D	FRONT RAIL	1 PC

HARDWARE LIST		
ITEM	DESCRIPTION	QTY
1	JCBB BOLT M8 x 60mm 	4 PCS
2	JCBB BOLT M8 x 80mm 	2 PCS
3	WOOD DOWEL M10 x 40mm 	2 PCS
4	M8 Bran Nut 	2 PCS
5	Wood Button Dia 18.5mm 	6 PCS
6	M5 ALLEN KEY (BALL SHAPE) 	1 PC

STEP 1

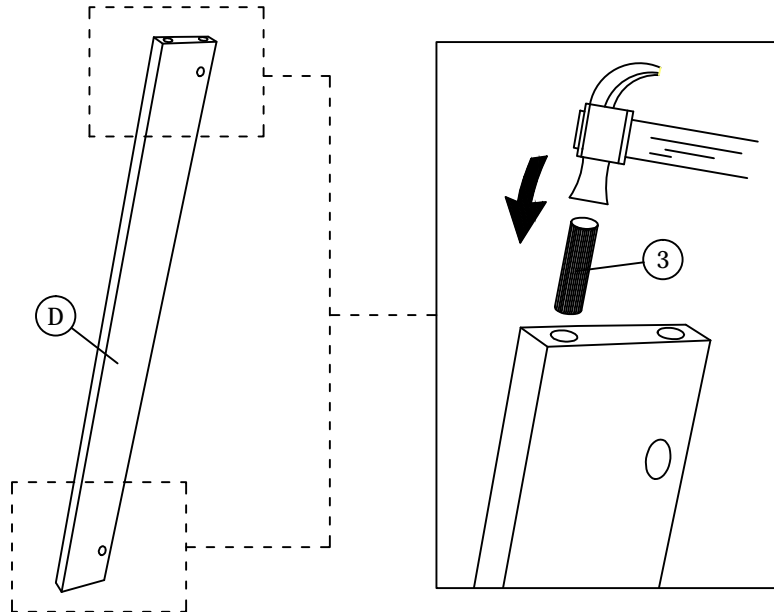

STEP 2

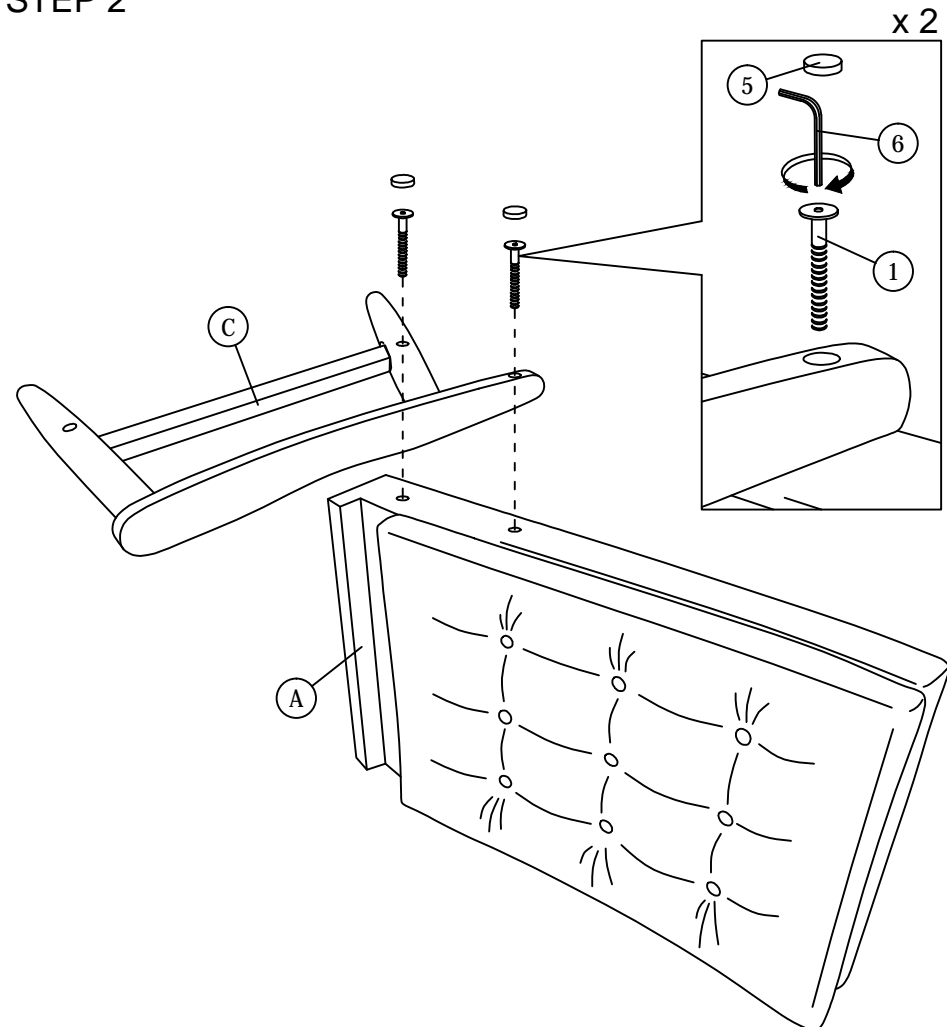

ASSEMBLY INSTRUCTIONS

2 of 2

STEP 3

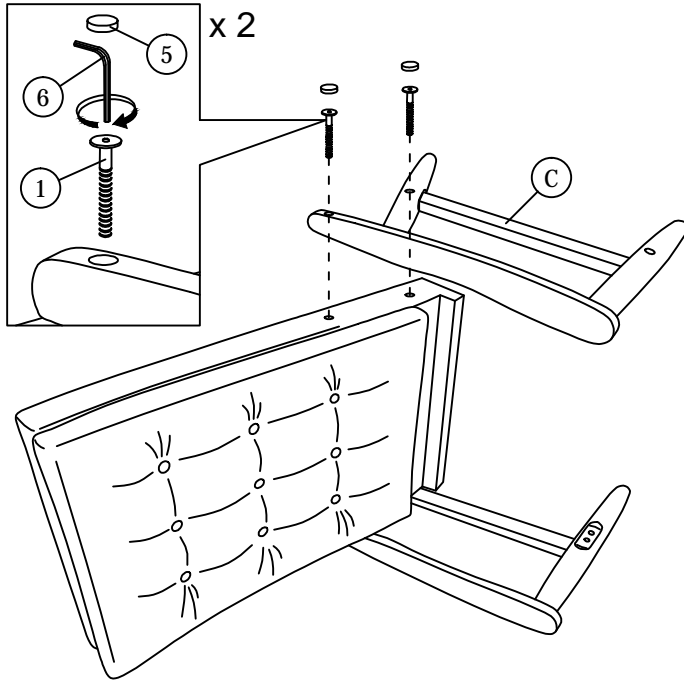

STEP 4

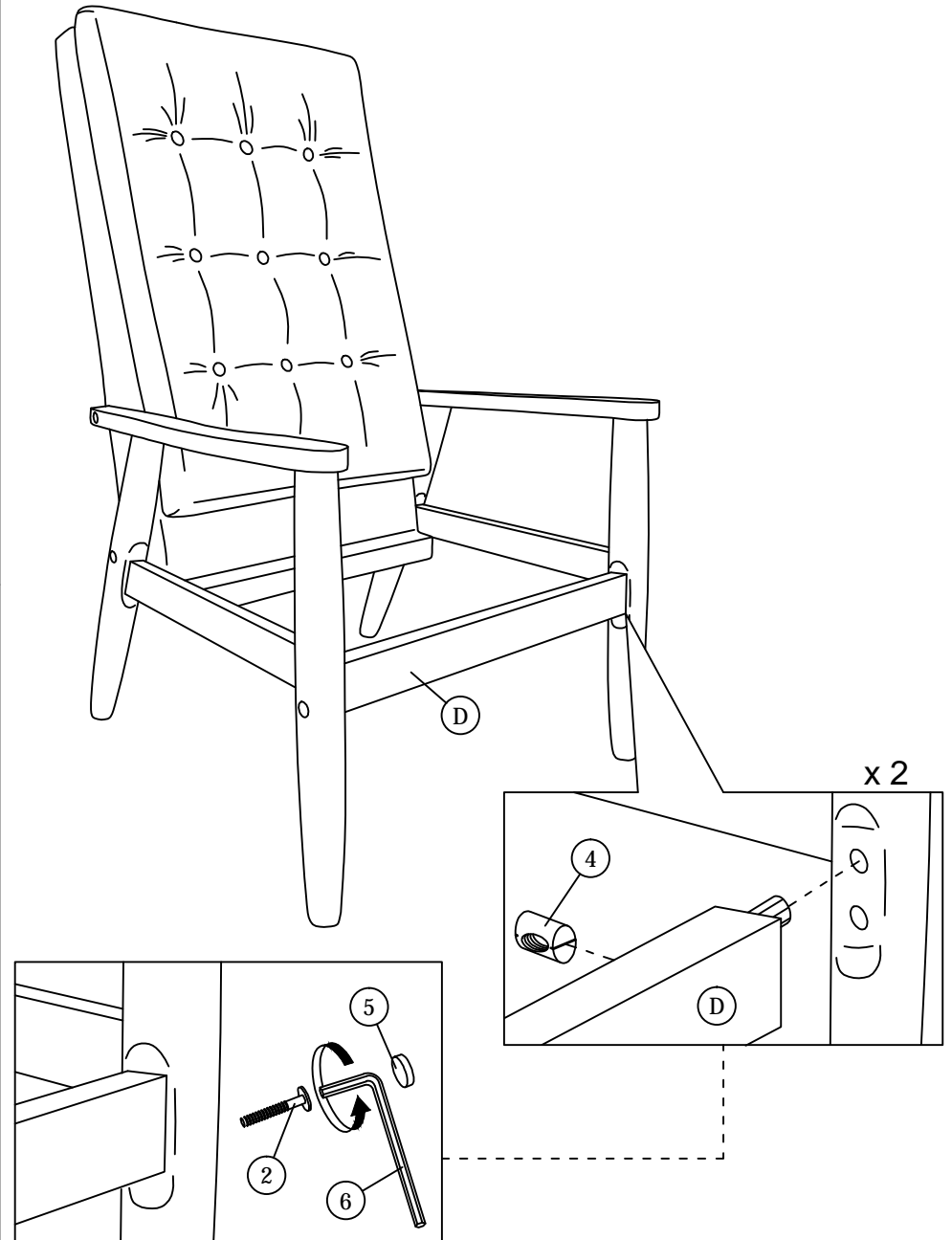

STEP 5

