





ASSEMBLY INSTRUCTIONS

MODEL : WM1342-DT5

IMPORTANT NOTE :

- * PLACE ALL WOODEN PARTS ON A CLEAN AND SMOOTH SURFACE SUCH AS A RUG OR CARPET TO AVOID THE PARTS FROM BEGIN SCRATCHED.
- * BEFORE YOU BEGIN, KINDLY FOLLOW THE ASSEMBLY INSTRUCTIONS STEP BY STEP.

HARDWARE LIST

A	JCBB SCREW M8 x 60mm		8PCS
B	SPRING WASHER 5/16"		8PCS
C	FLAT WASHER 5/16"		8PCS
D	ALLEN KEY M5		1PC

PART LIST

1	TABLE TOP	1PC
2	TABLE LEG	4PCS

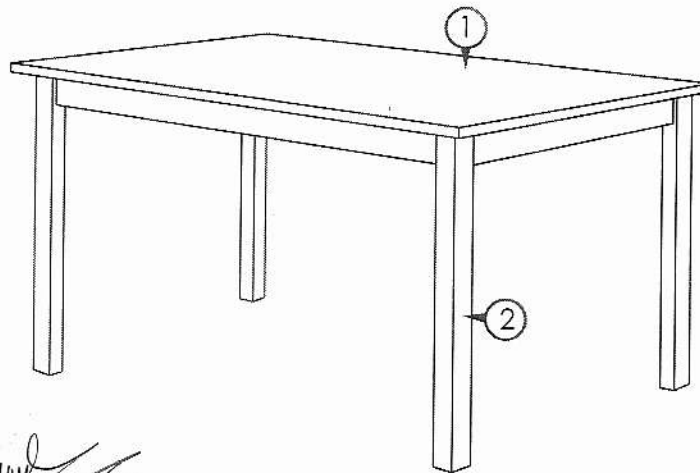

Shahid
6/5/2015

COMPLETED TABLE ASSEMBLY.

INSTRUCTION :-

(STEP 1)

Place Table Top (1) face down on a clean and flat surface to prevent from being scratched.

(STEP 2)

Position Table Leg (2) with E-Nut holes facing to Corner Block holes of Table Frame , then insert JCBB Screw (A) with Spring Washer (B), Flat Washer (C) then tighten with Allen Key (D) provided.

(STEP 3)

Repeat Step 2 for other 3 legs assembly.

(STEP 4)

Revert the table for completion of table assembly.

