







# Assembly Instruction

## SLAT BACK SIDE CHAIR

### HARDWARE PARTS :

					
Wood Screw 4 pcs	(Short) JCBC Bolt 4 pcs	(Long) JCBC Bolt 4 pcs	Lock Washer 8 pcs	Flat Washer 8 pcs	Allen Key 1 pce

### ASSEMBLY:

1. Position the chair back on a soft surface such as a carpet. Place the chair apron frame on to the chair back. Make sure that the screw holes on the apron frame are facing down.
  - 1.1 Insert the **JCBC Bolt (Short)** through a **Lock Washer** and a **Flat Washer** into the pre-drilled holes on the apron frame to the pre-drilled holes on the chair back.
2. Insert the **JCBC Bolt (Long)** through a **Lock Washer**, a **Flat Washer** and the pre-drilled holes of corner block into the pre-drilled holes on the front leg, tighten the **JCBC Bolt** with **Allen Key** provided.

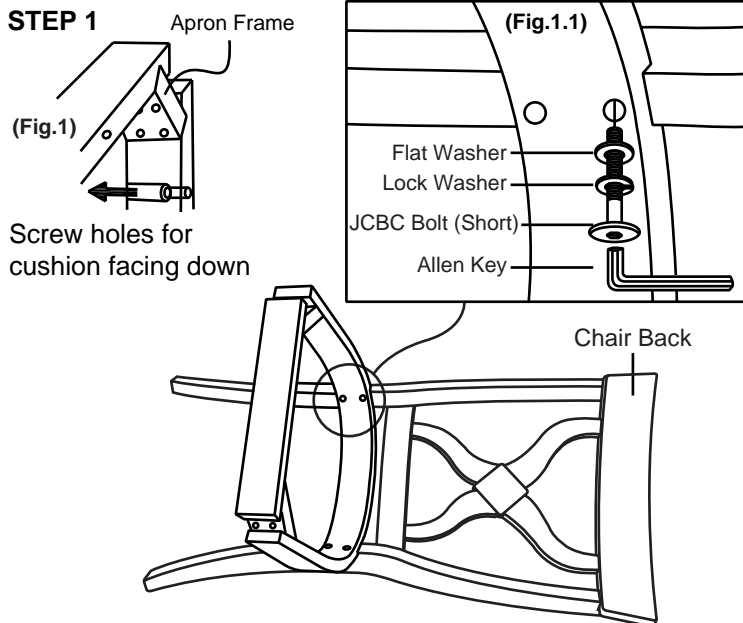

### STEP 2

Assemble front leg as shown.

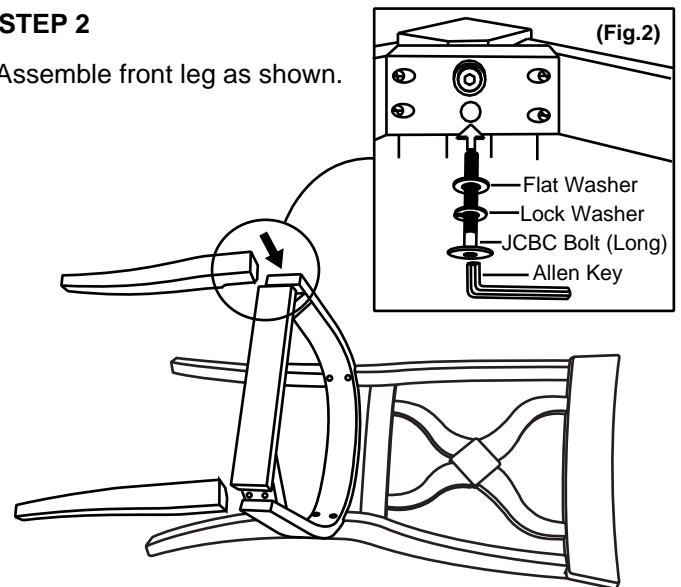

### STEP 3

Flip chair upside down and secure the cushion with the **Wood Screw** through the pre-drilled holes on the apron frame.

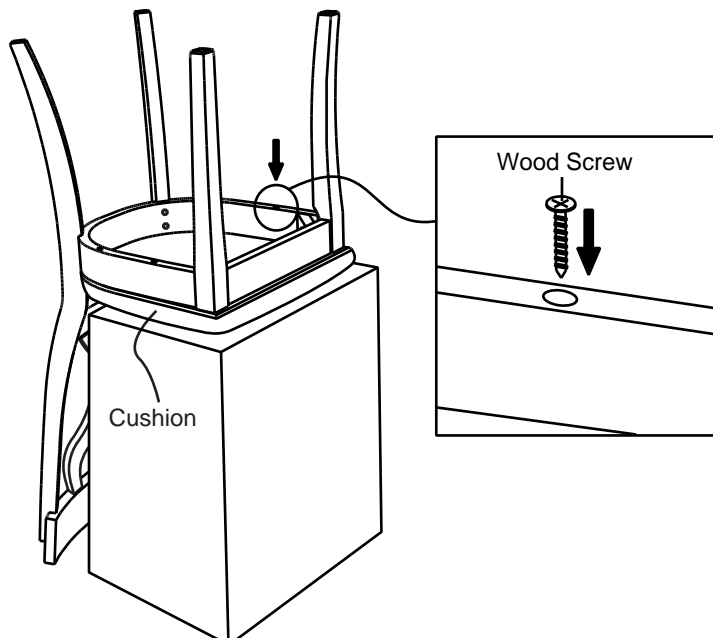

### STEP 4

Turn the chair upright. Check its balance and tighten all screws and bolts to complete the assembly.

