







Assembly Instruction

X-SHIELD BACK SIDE CHAIR

HARDWARE PARTS:

					
WOOD SCREW 6 PCS	(LONG) JCBC BOLT 8 PCS	(SHORT) JCBC BOLT 2 PCS	LOCK WASHER 10 PCS	FLAT WASHER 10 PCS	ALLEN KEY 1 PCE

ASSEMBLY:

1. POSITION THE CHAIR BACK ON A SOFT SURFACE SUCH AS A CARPET. PLACE THE CHAIR APRON FRAME ON TO THE MIDDLE RAIL OF THE CHAIR BACK WITH THE DOWEL FULLY INSERTED INTO THE PRE-DRILLED HOLES. MAKE SURE THAT THE SCREW HOLES ON THE APRON FRAME ARE FACING DOWN.
 - 1.1. INSERT JCBC BOLT (LONG) THROUGH A LOCK WASHER AND A FLAT WASHER INTO THE PRE-DRILLED HOLES ON THE APRON FRAME AT REAR CORNERS.
 - 1.2. INSERT THE JCBC BOLT (SHORT) THROUGH A LOCK WASHER AND A FLAT WASHER INTO THE PRE-DRILLED HOLES ON THE APRON FRAME AT REAR RAIL.
2. INSERT THE JCBC BOLT (LONG) THROUGH A LOCK WASHER, A FLAT WASHER AND THE PRE-DRILLED HOLES OF CORNER BLOCK INTO THE PRE-DRILLED HOLES ON THE FRONT LEG, TIGHTEN THE JCBC BOLT WITH ALLEN KEY PROVIDED.

(STEP 1)

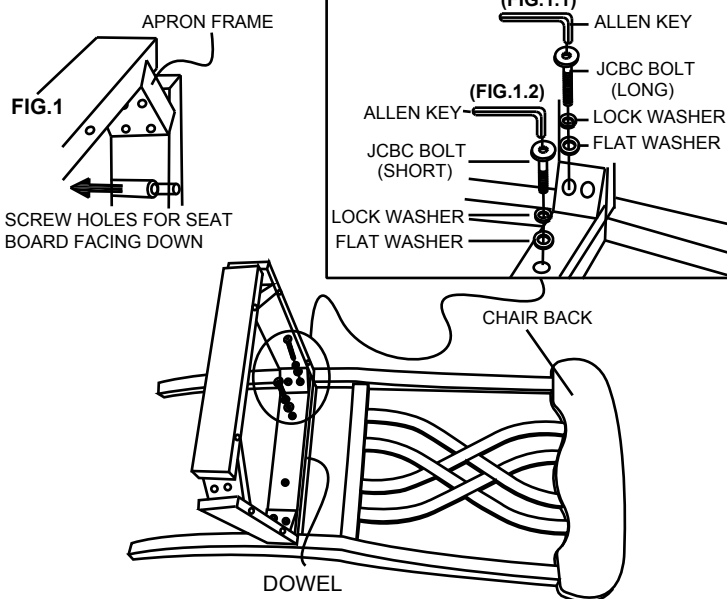

(STEP 2)

ASSEMBLE FRONT LEG AS SHOWN

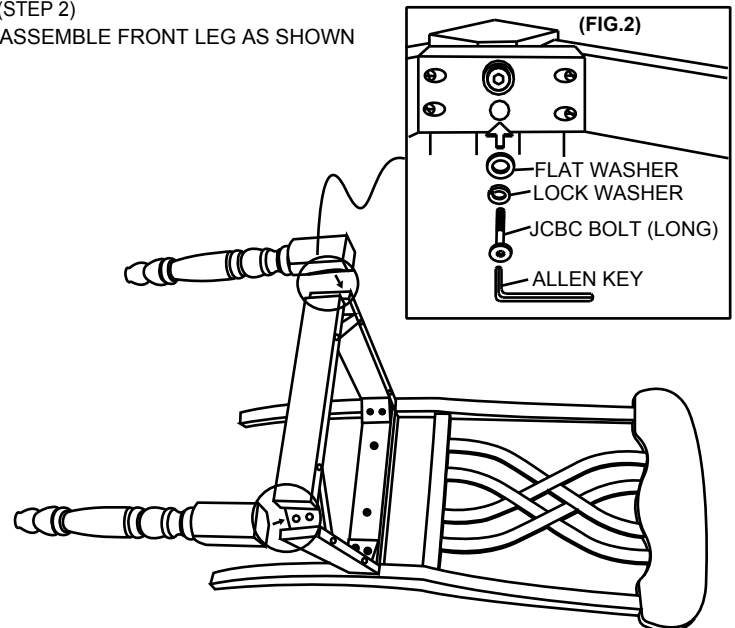

FIG. 3

3. FLIP CHAIR UPSIDE DOWN AND SECURE THE HARDSEAT WITH THE WOOD SCREW THROUGH THE PRE-DRILLED HOLES ON THE APRON FRAME.

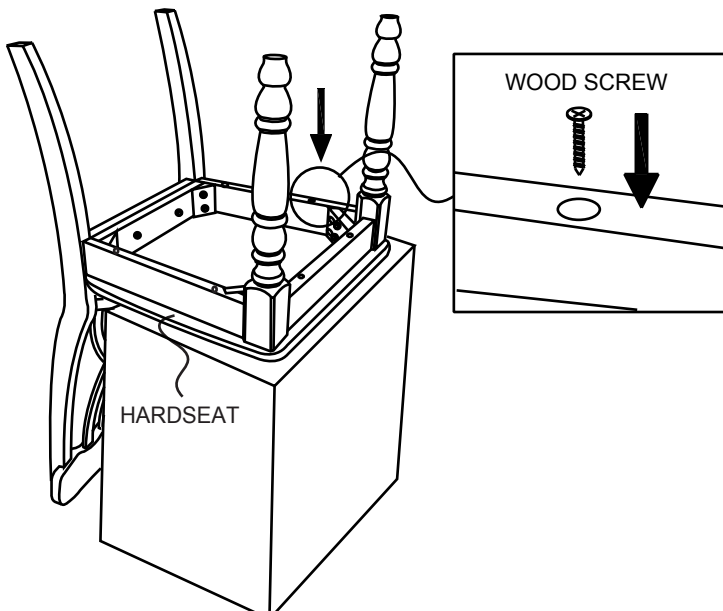

FIG. 4

4. TURN THE CHAIR UPRIGHT. CHECK IT'S BALANCE AND TIGHTEN ALL SCREWS AND BOLTS TO COMPLETE THE ASSEMBLY.

